

MultiSteril FAST

<i>Istruzioni per l'uso</i>	<i>ITALIANO</i>
<i>Instructions for use</i>	<i>ENGLISH</i>
<i>Mode d'emploi</i>	<i>FRANCAIS</i>
<i>Instrucciones de uso</i>	<i>ESPAÑOL</i>
<i>Bedienungsanleitung</i>	<i>DEUTSCH</i>
<i>Instruções para o uso</i>	<i>PORTUGUÊS</i>

Questo apparecchio assolve ai criteri di conformità CE in quanto conforme alla direttiva 93/42/CEE.
La dichiarazione di conformità originale è fornita in allegato al manuale.

This device compliance to Directive 93/42/CE.
The original declaration of conformity is provided in attached to the manual.

Cet appareil est conforme aux prescriptions CE puisque il respecte la instruction 93/42/CEE.
La déclaration de conformité est jointe au manuel d'usage.

El dispositivo es conforme con los criterios CE ya que respecta la norma 93/42/CE.
La declaración original es incluida en el manual de uso.

Das Gerät stimmt mit CE Norm. Es beachtet die Norm 93/42/EWG.
Die Original Konformitätserklärung ist der Gebrauchsanleitung beigelegt.

Este aparelho satisfaz os critérios de conformidade CE, pois é conforme com a diretiva 93/42/CEE.
A declaração de conformidade original é fornecida anexada ao manual.

INDICE

1. IMPIEGO E DESTINAZIONE D'USO DEL DISPOSITIVO

2. SICUREZZA

- 2.1 MARCATURA DI SICUREZZA
- 2.2 DISPOSITIVI DI SICUREZZA
- 2.3 SMALTIMENTO

3. DATI TECNICI

4. DISIMBALLAGGIO

5. COMPONENTI

6. INSTALLAZIONE

- 6.1 COLLEGAMENTI
- 6.2 RIEMPIMENTO SERBATOIO DETERGENTE

7. FUNZIONAMENTO DELL'APPARECCHIO

- 7.1 PLANCIA COMANDI
- 7.2 SELEZIONE LINGUA
- 7.3 SELEZIONE CICLO
- 7.4 IMPOSTAZIONE STANDARD DEI CICLI
- 7.5 MODIFICA DEI CICLI
- 7.6 IMPOSTAZIONE PARTENZA RITARDATA

8. ISTRUZIONI DI UTILIZZO

9. MANUTENZIONE

- 9.1 PULIZIA
- 9.2 PULIZIA DELLA VASCA
- 9.3 PULIZIA DEL FILTRO VASCA
- 9.4 PULIZIA DEL FILTRO DI INGRESSO ACQUA
- 9.5 PULIZIA DELLA SONDA
- 9.6 MANUTENZIONE PROGRAMMATA

10. SEGNALAZIONI – ERRORI

- 10.1 SEGNALAZIONI
- 10.2 ERRORI
- 10.4 PROBLEMI GENERICI

11. PROCEDURE PER SERVIZIO ED ASSISTENZA

A. ACCESSORI

B. DISEGNI

1

IMPIEGO E DESTINAZIONE D'USO

DESTINAZIONE D'USO	La vasca multifunzione è stata progettata per rimuovere fisicamente i residui organici e inorganici ed asciugare lo strumentario utilizzato in ambito medico, dentale, estetico e veterinario.
---------------------------	---

Il dispositivo tramite detersione ad ultrasuoni permette di pulire in punti difficilmente raggiungibili con la pulizia manuale e senza i rischi causati dalla manipolazione degli strumenti contaminati.

Il dispositivo può memorizzare 3 cicli, impostabili dall'utilizzatore.

Le fasi principali sono:

DETERSIONE	Fase che riduce di oltre il 90% l'entità della contaminazione microbica. Tale fase rimuove il materiale organico e inorganico.
RISCIACQUO	Tale fase rimuove eventuali residui di detergente presenti all'interno della vasca.
ASCIUGATURA	Dopo il risciacquo i dispositivi devono essere asciugati per evitare residui di acqua che possono compromettere il successivo processo di sterilizzazione



La vasca multifunzione deve essere utilizzata esclusivamente per la detersione di strumenti e materiali compatibili con il sistema di lavaggio ad ultrasuoni ed in generale esclusivamente per gli usi previsti dal costruttore.

2

SICUREZZA



L'apparecchio non deve essere utilizzato in atmosfera potenzialmente esplosiva.



Posizionare l'apparecchio lontano da fonti di calore o di radiazioni elettromagnetiche.



Posizionare l'apparecchiatura in modo che la plancia comandi e lo schermo siano chiaramente visibili da parte dell'operatore.



L'impianto elettrico deve essere conforme alla normativa vigente, verificare che l'impianto sia adeguato alle caratteristiche del dispositivo.



Controllare l'integrità del cavo di alimentazione.



Non utilizzare detergenti infiammabili



Non immettere acidi (es HCl) o cloruri nella vasca



Non inserire oggetti a contatto con il fondo della vasca



Il produttore è responsabile del prodotto immesso sul mercato ai sensi della normativa vigente. La responsabilità decade nel momento in cui vengono eseguite operazioni sul dispositivo, o su parte di esso, da personale non qualificato o con l'utilizzo di parti di ricambio non originali.

**NON APRIRE L'APPARECCHIO.**

In caso di guasti o pericolo di intrusione di liquido nell'apparecchio, in caso di manutenzione e pulizia dell'apparecchio scollegare il cavo di alimentazione elettrica.



Non rimuovere la targhetta



Prima di qualsiasi intervento disinserire il cavo d'alimentazione dalla presa di corrente.



Seguire le indicazioni riportate sulla scheda di sicurezza del liquido utilizzato.



Gli ultrasuoni in determinate condizioni possono produrre rumori spiacevoli per l'udito. Indossare DPI idonei.

2.1 Marcatura di sicurezza

	<p>TENSIONE PERICOLOSA</p>
 <p>ATTENZIONE ATTENTION ATTENTION ACHTUNG</p> <p>ALTA TEMPERATURA HIGH TEMPERATURES TEMPERATURES ELEVEES HOHE TEMPERATUR</p>	<p>ALTA TEMPERATURA</p>
	<p>CONNESSIONE A TERRA</p>

2.2 Dispositivi di sicurezza

-) Sensore apertura sportello
-) Termostati di sicurezza
-) Sistema di controllo carico acqua

2.3 Smaltimento



Questo prodotto è soggetto alla direttiva 2002/96/EC del Parlamento europeo e del Consiglio dell'Unione europea sui rifiuti di apparecchiature elettriche (RAEE). Nelle giurisdizioni che adottano tale direttiva, il prodotto è stato lanciato sul mercato in data successiva al 13 agosto 2005 e non deve essere smaltito come rifiuto domestico non riciclabile. Utilizzare le apposite strutture RAEE di raccolta locali per lo smaltimento di questo prodotto oppure attenersi alle disposizioni vigenti.

3

DATI TECNICI

MECCANICI		
Temperatura di lavoro	+5°C ÷ +30°C	
Umidità relativa MAX a 30°C	80%	
Dimensioni ingombro (LxHxP)	415 x 415 x 530 mm	
Altezza coperchio aperto	750 mm	
Profondità coperchio aperto	530 mm	
Peso (serbatoio vuoti)	20 kg	
ELETTRICI		
Tensione alimentazione	230 V a.c. +/-10 % single phase	
Potenza MAX assorbita	1 kW	
Frequenza	50 / 60 Hz	
Cavo alimentazione	2 + 1 x 1mm ²	
Fusibili	6.3 A (5 x 20)	
ULTRASUONI		
N° trasduttori	4	
Frequenza	39 KHz	
ALIMENTAZIONE IDRICA		
Pressione acqua	1.5÷2 bar	
Conducibilità dell'acqua	> 50 µS/cm	
Temperatura MAX	+30°C	
Dimensioni tubo alimentazione	3/4 G - lunghezza 3 m	
VASCA		
Volume vasca	9 l (Acciaio inox AISI 316)	
Volume carico acqua	6 l	
SERBATOIO DETERGENTE		
Volume	1.5 l + 0.5 l (riserva)	
Cicli eseguibili con serbatoio pieno	Percentuale selezionata	Cicli eseguibili*
	1%	≈25
	2%	≈12
	3%	≈8
	4%	≈6
	5%	≈5
	6%	≈4
Materiale	Polietilene	
FILTRI		
Filtro vasca	Acciaio inox AISI 304	

L'imballo non deve subire urti, deve essere maneggiato con cura evitando di farlo rotolare o farlo cadere.

Il dispositivo è supportato con un pallet in legno e racchiuso in un cartone ondulato e rinforzato internamente da composti di cartone.

Aprire il cartone ondulato, rimuovere le parti di rinforzo ed estrarre il dispositivo utilizzando esclusivamente le cinghie in dotazione.



La movimentazione dell'apparecchio deve avvenire solo con l'utilizzo delle cinghie. Non sollevare mai prendendo il dispositivo dal quadro comandi. Tale operazione errata potrebbe danneggiare l'apparecchiatura.



L'imballo deve essere conservato per tutto il periodo di garanzia. Il fabbricante non accetta resi senza imballo originale.



Non utilizzare apparecchi che presentano danni evidenti dovuti al trasporto.



Togliere l'imballo e controllare lo stato dell'apparecchio.

CONTENUTO:

- **VASCA MULTIFUNZIONE**
- **MANUALE D'USO:** Da leggere attentamente e riporre in un luogo accessibile a tutti gli operatori addetti al funzionamento del dispositivo.
- **DICHIARAZIONE DI CONFORMITA'** : da conservare.
- **VERBALE DI INSTALLAZIONE - COLLAUDO E CONDIZIONI DI GARANZIA:** Da compilare al momento dell'installazione della macchina seguendo le indicazioni indicate sul modulo.
- **GUIDA RAPIDA DI UTILIZZO:** Da conservare in prossimità della macchina.
- Tubo di alimentazione idrica
- Tubo di scarico
- Tubo sfiato detergente
- Cavo di alimentazione
- Cestello standard
- Cestello porta-frese
- Confezione detergente consigliato

05**DESCRIZIONE DEI COMPONENTI**

Fare riferimento ad **Appendice B – DISEGNI**

G	Resistenza asciugatura
H	Ugelli acqua
I	Ugello detergente
J - Y	Sonda
K	Tastiera e LCD
L	Interruttore generale
M	Spina alimentazione con portafusibili
N	Sfiato serbatoio detergente con funzione di troppopieno
O	Ingresso acqua (3/8 G)
P	Raccordo scarico
R	Molla a gas
U	Guarnizione coperchio
V	Collettore detergente
Z	Vasca inox



L'apparecchio non deve essere utilizzato in atmosfera potenzialmente esplosiva.



Posizionare l'apparecchio lontano da fonti di calore o di radiazioni elettromagnetiche.



Posizionare l'apparecchio in modo che la plancia comandi e lo schermo siano chiaramente visibili da parte dell'operatore.



L'impianto elettrico deve essere conforme alla normativa vigente, verificare che l'impianto sia adeguato alle caratteristiche del dispositivo.

Aprire il coperchio ed estrarre gli accessori contenuti nella vasca.

Posizionare su una superficie perfettamente orizzontale, stabile e resistente a carichi di almeno **35 kg**. I supporti del dispositivo sono regolabili e permettono minimi aggiustamenti.



Una errata pendenza causa la permanenza di un film di acqua sul fondo della vasca con problemi di asciugatura

Posizionare il dispositivo in modo tale da permettere all'operatore di ispezionare e pulire agevolmente la vasca; l'operatore deve poter accedere al retro del dispositivo per la pulizia del filtro.

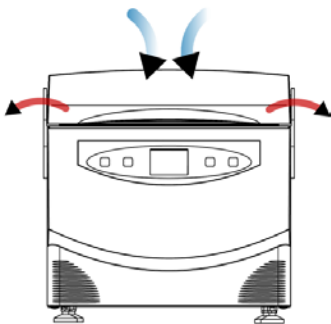

L'asciugatura prevede che venga prelevata aria dalla parte posteriore e scaricata aria calda dai lati del dispositivo.

Lasciare almeno 50 mm di spazio libero sui lati.

6.1 Collegamenti

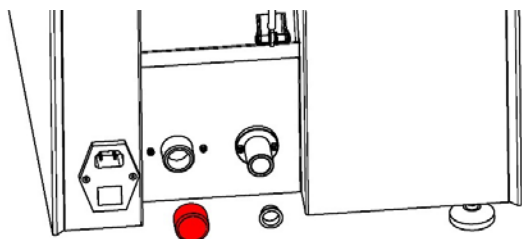

Togliere i tappi di protezione.

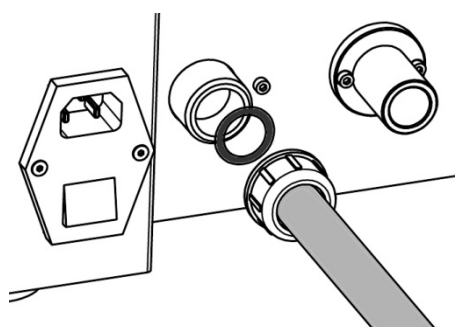

Tubo di carico acqua.

Collegare il tubo al dispositivo (O) inserendo l'apposita guarnizione in gomma. Collegare l'altra estremità al rubinetto di alimentazione.

OPZIONALE: sistema di blocco di emergenza del flusso d'acqua (WATER BLOCK). Tale dispositivo deve essere installato subito a valle del rubinetto di alimentazione in posizione verticale. Vedere le istruzioni del dispositivo per maggiori informazioni sull'installazione ed uso dello stesso.

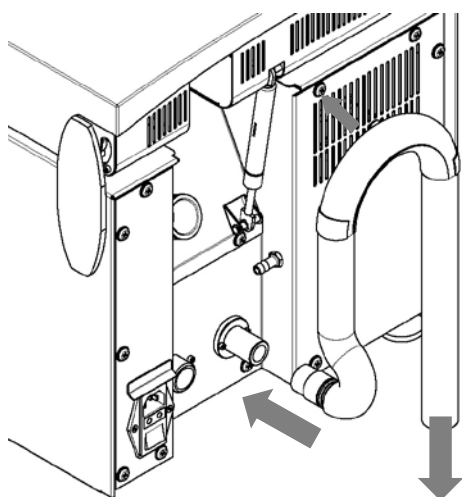

Tubo di scarico dell'acqua.

Togliere il tappo di protezione. Collegare il tubo al dispositivo (P). Collegare l'altra estremità allo scarico. Fissare in modo stabile e sicuro.



Installare il sifone come in figura.

Tubo sfiato serbatoio detergente

Portare il tubo di sfiato trasparente in dotazione in un punto visibile all'altezza del piano di appoggio della macchina o al disotto. Non ostruire o tenere immerso nel liquido. Il tubo di sfiato ha anche funzione di troppopieno, quando il serbatoio del detergente è pieno, se si inserisce ancora detergente, viene scaricato dal tubo di sfiato.

Cavo di alimentazione



Controllare l'integrità del cavo di alimentazione.

Collegare il cavo di alimentazione alla presa posta sul retro del dispositivo (M).



Evitare di connettersi con prolunghe, riduzioni od adattatori

Accendere la macchina tramite l'apposito interruttore (L).

Aprire il rubinetto di alimentazione acqua e controllare che il tubo di carico non presenti perdite (se perde stringere ulteriormente i raccordi, e controllare siano presenti le guarnizioni).



Controllare la presenza del filtro in vasca e la pulizia dello stesso.

6.2 Riempimento serbatoio detergente:

Il serbatoio ha una capacità di circa 2 l di cui 0.5 l di riserva.

Durante il riempimento il dispositivo deve essere acceso e visualizzare 'SELEZIONE CICLO'.



ACCENDERE SEMPRE LA MACCHINA PRIMA DI CARICARE IL SERBATOIO DEL DETERGENTE

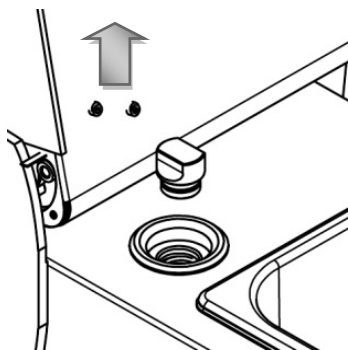

Aprire il coperchio della vasca e sollevare il tappo (V) posto sul lato sinistro della vasca.

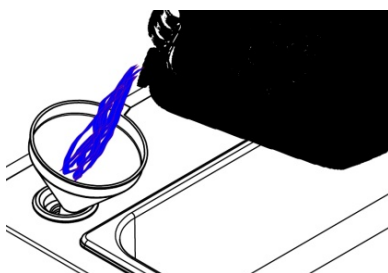

Inserire il liquido detergente (preferibilmente con l'utilizzo di un imbuto in dotazione) fino a quando un segnale acustico/visivo (sul display) comunicherà che il serbatoio è pieno



Utilizzare solo liquidi raccomandati dal fabbricante.



Non mescolare liquidi all'interno del serbatoio in quanto le reazioni chimiche risultanti possono provocare danni consistenti al dispositivo.

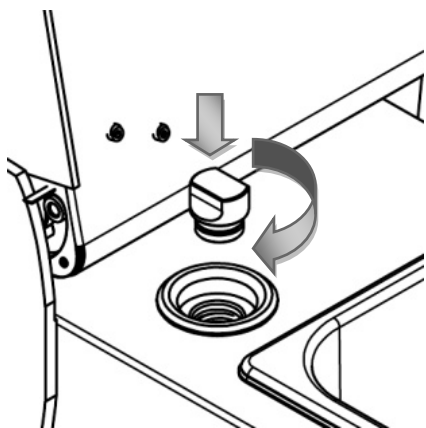

Premere e ruotare leggermente per chiudere il tappo ingresso detergente.



È importante chiudere il tappo ingresso detergente per evitare che il detergente cristallizzi, la cristallizzazione del detergente potrebbe causare l'ostruzioni e il danneggiamento di alcuni componenti.

7



FUNZIONAMENTO DELL'APPARECCHIO

Il dispositivo multifunzione presenta un coperchio sollevabile per l'accesso alla vasca di lavaggio.

All'interno della vasca di lavaggio occorre posizionare l'apposito cestello, **dotato di supporti in gomma**, riempito con gli oggetti da pulire.

Il dispositivo multifunzione ha un serbatoio interno adibito a contenere un detergente che viene dosato ed iniettato automaticamente nella vasca di lavaggio durante il ciclo.

Un ciclo di lavaggio completo prevede le fasi riportate nella tabella seguente.

FASE	SIMBOLO	DESCRIZIONE	DURATA																																			
1		<p>Caricamento acqua</p> <p>L'acqua entra nella vasca, superando il bordo del cestello di circa 2 mm. Il volume totale è di circa 6 l.</p>	<p>1.5 min (P ingresso = 2.5 bar)</p>																																			
2		<p>Ingresso detergente</p> <p>Una pompa dosa automaticamente e trasferisce dal serbatoio interno alla vasca la quantità impostata di detergente:</p> <table border="1" data-bbox="539 1272 1134 1783"> <thead> <tr> <th>Percentuale selezionata</th> <th>Volume (ml)</th> <th>Cicli eseguibili*</th> </tr> </thead> <tbody> <tr> <td>1%</td> <td>60</td> <td>≈25</td> </tr> <tr> <td>2%</td> <td>120</td> <td>≈12</td> </tr> <tr> <td>3%</td> <td>180</td> <td>≈8</td> </tr> <tr> <td>4%</td> <td>240</td> <td>≈6</td> </tr> <tr> <td>5%</td> <td>300</td> <td>≈5</td> </tr> <tr> <td>6%</td> <td>360</td> <td>≈4</td> </tr> </tbody> </table> <p><i>* Con il serbatoio pieno (1500 ml)</i></p>	Percentuale selezionata	Volume (ml)	Cicli eseguibili*	1%	60	≈25	2%	120	≈12	3%	180	≈8	4%	240	≈6	5%	300	≈5	6%	360	≈4	<table border="1" data-bbox="1236 1272 1380 1783"> <thead> <tr> <th>%</th> <th>sec</th> </tr> </thead> <tbody> <tr> <td>1</td> <td>80</td> </tr> <tr> <td>2</td> <td>160</td> </tr> <tr> <td>3</td> <td>240</td> </tr> <tr> <td>4</td> <td>320</td> </tr> <tr> <td>5</td> <td>400</td> </tr> <tr> <td>6</td> <td>480</td> </tr> </tbody> </table>	%	sec	1	80	2	160	3	240	4	320	5	400	6	480
Percentuale selezionata	Volume (ml)	Cicli eseguibili*																																				
1%	60	≈25																																				
2%	120	≈12																																				
3%	180	≈8																																				
4%	240	≈6																																				
5%	300	≈5																																				
6%	360	≈4																																				
%	sec																																					
1	80																																					
2	160																																					
3	240																																					
4	320																																					
5	400																																					
6	480																																					

3		<p>Riscaldamento</p> <p>Il dispositivo procede per 5 minuti al riscaldamento e a una prima decontaminazione degli strumenti. Se non raggiunge la temperatura, il riscaldamento continua anche durante il lavaggio.</p>	5 min ¹
4	 <p>LAMPEGGIANTE</p>	<p>Degassificazione (DEGAS)</p> <p>Il dispositivo per 5 minuti procede attivando ad intermittenza gli ultrasuoni. Questo processo riduce i gas disciolti nel liquido migliorando l'efficienza del successivo lavaggio.</p>	5 min ¹
4S	<p>PREMERE START PER CONTINUARE</p>	<p>STANDBY</p> <p>Questa fase innovativa permette di gestire processi importanti come:</p> <ul style="list-style-type: none"> - Mantenere gli strumenti nel liquido di lavaggio (AMMOLLO) - Aggiungere strumenti (ATTENZIONE: MAX 1 KG di acciaio) <p>PER USCIRE DALLA FASE DI STANDBY E PORTARE A TERMINE IL CICLO AUTOMATICAMENTE È NECESSARIO PREMERE START.</p>	
5		<p>Lavaggio ad ultrasuoni</p> <p>Fase di lavaggio tramite cavitazione ultrasonora.</p> <p>SWEEP</p> <p>Gli ultrasuoni vengono modulati in frequenza riducendo gli effetti negativi delle onde stazionarie aumentando la distribuzione dell'energia ultrasonora nel liquido di lavaggio.</p> <p>La pulizia è più efficiente (migliora la cavitazione)</p>	<p>da 1 min a 30 min</p>
6		<p>Scarico</p> <p>La vasca si svuota automaticamente</p>	≈ 1.5 min

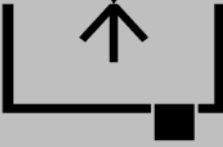
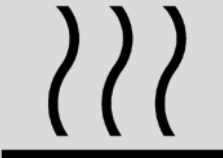
7		<p>Secondo caricamento acqua</p> <p>La vasca viene nuovamente riempita per risciacquare gli strumenti</p>	<p>1.5 min (P ingresso = 2.5 bar)</p>
8		<p>Risciacquo ad ultrasuoni</p> <p>Attivazione per breve periodo degli ultrasuoni, risciacquo tramite cavitazione.</p>	<p>1 min</p>
9		<p>Scarico</p> <p>La vasca si svuota automaticamente</p>	<p>≈ 1.5 min</p>
10		<p>Asciugatura</p> <p>Per asciugare gli strumenti, la macchina genera un flusso di aria calda che lambisce gli oggetti e ne asporta l'umidità sotto forma di vapore.</p>	<p>15 min</p>

Note:

1 Le fasi di riscaldamento e degassificazione, se impostate entrambe, vengono effettuate contemporaneamente per una durata totale di 5 minuti.

7.1 Plancia comandi

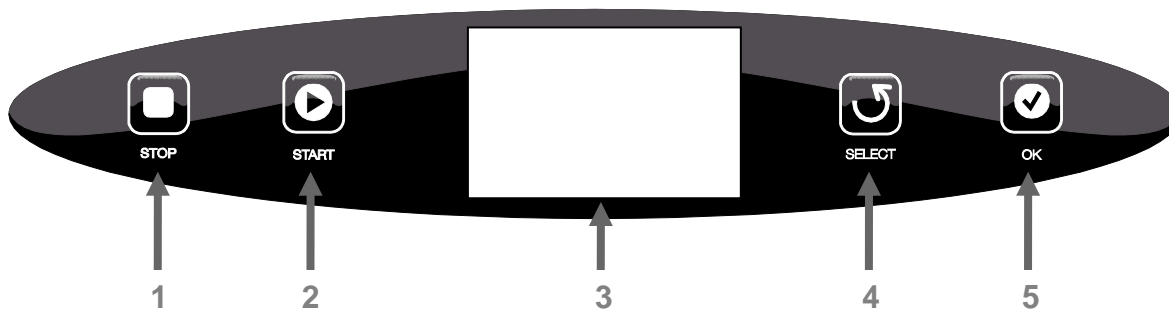

TASTI AVVIO/INTERRUZIONE CICLO

1	STOP - ANNULLA IL CICLO IN ESECUZIONE
2	START - AVVIO CICLO

TASTI DI PROGRAMMAZIONE

4	SELECT - PULSANTE DI NAVIGAZIONE
5	OK - CONFERMARE LA SELEZIONE E PASSARE ALLA SEZIONE SUCCESSIVA
3	DISPLAY

7.2 Selezione lingua

Premere **STOP** per 8 secondi.

Il display visualizza la lingua impostata.

Premere **SELECT** per scorrere le lingue disponibili.

Premere **OK** per confermare la lingua selezionata.

7.3 Selezione ciclo

All'accensione compare sul display il logo del fabbricante e la versione del firmware.

Trascorsi 3 secondi il display visualizza:

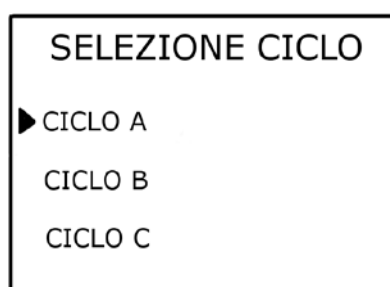

Premere **SELECT** per scorrere i programmi.

Premere **START** per avviare il ciclo selezionato.

7.4 Impostazione standard dei cicli

Il dispositivo viene rilasciato con le seguenti impostazioni di fabbrica:

	A	B	C
Standby	ON	OFF	OFF
Ingresso detergente	1 %	1 %	1 %
Riscaldamento	ON	OFF	ON
Funzione Degas	SI	SI	SI
Funzione SWEEP	NO	SI	NO
Lavaggio ad ultrasuoni	20 min	20 min	5 min
Asciugatura	SI	SI	SI

Le impostazioni sono modificabili a piacimento per tutti i cicli.

7.5 Modifica dei cicli

Selezionare il ciclo che si desidera modificare.

Premere il pulsante **OK** per visualizzare il MENU.

Impostazioni disponibili:

Descrizione	Impostazioni	Step
Standby	ON - OFF	-
Ingresso detergente	0 ÷ 6 %	1%
Riscaldamento	ON - OFF	-
Funzione Degas	SI - NO	-
Funzione SWEEP	SI - NO	-
Lavaggio ad ultrasuoni	0 ÷ 30 min	1 min
Asciugatura	SI - NO	-

Premere il tasto **OK** per scorrere i parametri del ciclo.

Premere il tasto **SELECT** per modificare il valore del parametro selezionato.

Il menu dei parametri e delle impostazioni sono a scorrimento circolare.

Completate le impostazioni selezionare EXIT e premere **SELECT** per uscire dal MENU.

Le modifiche verranno salvate.

7.6 Impostazione PARTENZA RITARDATA:

Premere **START** per 8 secondi.

Premere **SELECT** per passare scorrere i valori da 1 a 9 ore.

Premere **START** per avviare la partenza ritardata.

Durante l'attesa comparirà un timer per visualizzare il tempo mancante all'avvio del ciclo.

ATTENZIONE: In caso di mancata tensione si annulla la partenza ritardata.

8

ISTRUZIONI DI UTILIZZO

Aprire il rubinetto di alimentazione acqua. Controllare la presenza del filtro in vasca e la pulizia dello stesso. Posizionare gli oggetti da trattare nell'apposito CESTELLO, se sono presenti oggetti di piccole dimensioni, utilizzare l'apposito PORTAFRESE in dotazione.

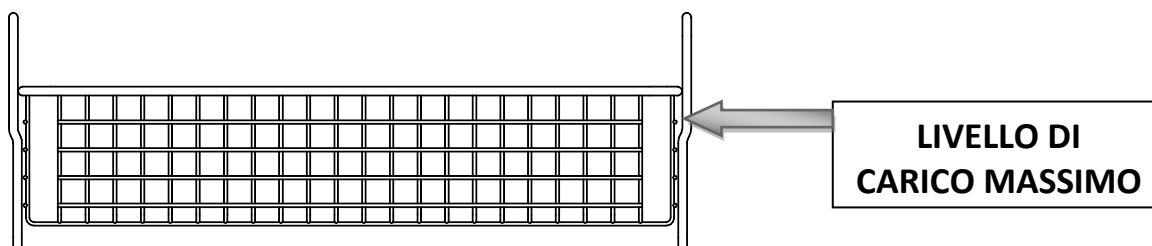

Il carico deve essere fatto distribuendo uniformemente gli oggetti da lavare che non devono urtare le pareti o il fondo della vasca.

Inserire il cestello all'interno della vasca prestando attenzione a non creare contatto tra pareti vasca e cestello.

È importante pre-trattare cementi, alginati e compositi con liquidi specifici.

Se gli oggetti presentano sporco grossolano, occorre asportarlo prima di inserire gli strumenti nel cestello per evitare di ostruire il filtro di scarico.

Per escludere il contatto tra i piedini del cestello in acciaio e la vasca di lavaggio in acciaio vengono inseriti appositi anelli in gomma. Se dovessero risultare danneggiati o mancanti, inserire gommini nuovi. L'utilizzo errato può causare danni alla vasca. Accendere la macchina tramite l'apposito interruttore (L).

Avviare il ciclo selezionato premendo **START** la macchina visualizza la fase del ciclo che sta eseguendo e il countdown del tempo (tempo stimato) necessario per completare il ciclo.

Se il ciclo prevede la fase di STANDBY è necessario premere una seconda volta **START** (dopo le fasi di carico acqua, ingresso, degas e riscaldamento) per passare alla fase di lavaggio e terminare il ciclo impostato.

Al termine del ciclo viene visualizzato ' **END CYCLE OK** ' accompagnato da un segnale acustico. Premere OK per riportarsi sulla selezione ciclo.

Se viene aperto lo sportello con il dispositivo in funzione, esso blocca automaticamente il processo in esecuzione.

Chiudendo il coperchio il ciclo riprenderà esattamente dal punto in cui è stato interrotto.



A fine giornata chiudere il rubinetto installato a monte del dispositivo.



Non toccare gli oggetti, il coperchio e la resistenza durante l'asciugatura. Pericolo di ustioni.



Svuotare completamente il serbatoio prima di inserirvi un detergente differente da quello precedentemente contenuto

Utilizzo di detergente diverso da quello contenuto nel serbatoio:

E' possibile utilizzare detergente diversi da quello contenuto all'interno del serbatoio.

Impostare, nel menu del ciclo che vogliamo eseguire, in riferimento all'ingresso automatico del detergente 'NO'.

Avviare il ciclo, dopo pochi minuti (al termine della fase di carico acqua) il dispositivo emette un segnale acustico, in questo momento e' possibile aprire il coperchio inserire direttamente nella vasca la percentuale (1% - 60ml) voluta di detergente.

Chiudere il coperchio per completare il ciclo.

Svuotamento serbatoio detergente:

Utilizzare il dispositivo, quando richiede di aggiungere detergente, se si vuole svuotare completamente il serbatoio del detergente, premere e tenere premuto il tasto **SELECT** e contemporaneamente premere e tenere premuto il tasto **OK**.

Dopo 5 secondi si avvia la pompa peristaltica, in questa fase è presente un segnale sonoro intermittente che si interrompe solo quando si termina la fase, il detergente verrà scaricato direttamente in vasca tramite l'ugello posto sul coperchio (I).

Dopo circa 10 min aprire leggermente il coperchio (senza far intervenire il sensore di apertura coperchio) e controllare che non esca detergente dall'ugello.

Terminato lo svuotamento interrompere il processo mediante il pulsante **STOP**.

9

MANUTENZIONE

9.1 Pulizia

La pulizia deve essere eseguita con dispositivo freddo e cavo di alimentazione non collegato.



Utilizzare detergenti non aggressivi per la plastica



Utilizzare detergenti idonei per l'acciaio inox

9.2 Pulizia della vasca



Verificare la pulizia della vasca alla fine di ogni ciclo

Asportare eventuali depositi o detriti per evitare di immettere nel circuito di scarico materiali che possono creare ostruzioni.

9.3 Pulizia del filtro vasca



Verificare la pulizia del filtro vasca alla fine di ogni ciclo

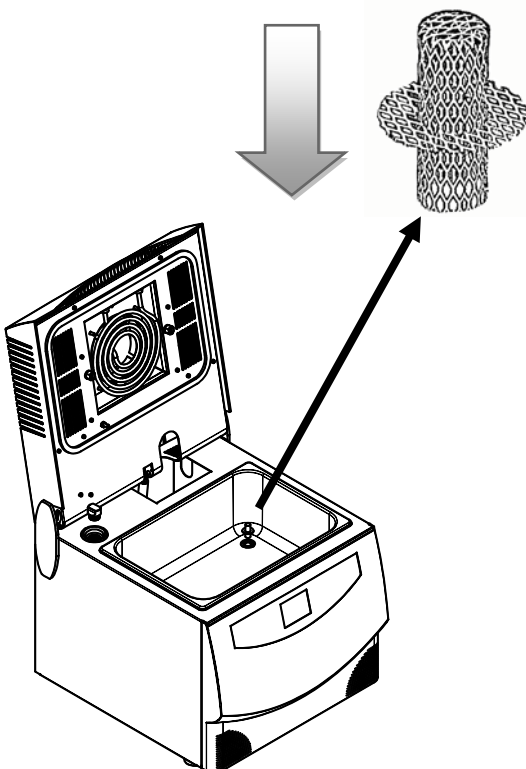

Sollevere il coperchio della macchina;

Rimuovere i residui presenti nella vasca.

Estrarre il filtro metallico presente nella vasca tirandolo verso l'alto come indicato in figura;

Lavare il filtro in acqua corrente per rimuovere tutte le impurità presenti.

Riposizionare il filtro nella sua sede facendo attenzione di inserire la parte aperta del filtro dentro al raccordo di scarico e quella chiusa a vista nella vasca.

9.4 Pulizia del filtro di ingresso acqua

Da controllare periodicamente

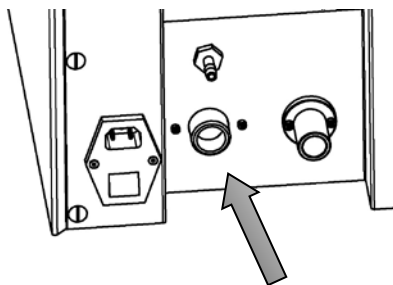

Chiudere l'alimentazione idrica, togliere il tubo di carico acqua, verificare che il filtro (O) sia pulito.

In caso contrario estrarlo con l'aiuto di una pinza senza forzare e pulirlo con acqua.

Rimontare il filtro e il tubo di alimentazione.

9.5 Pulizia della sonda livello

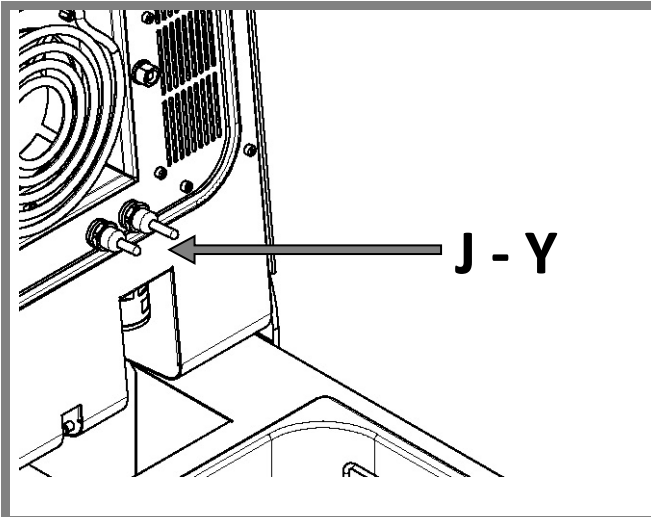

Controllare periodicamente (ogni 2-3 cicli) la **SONDA J e Y**.

Pulire la parte in metallo con prodotti idonei per acciaio inox oppure un decapante.

Utilizzare una spugna (leggermente abrasiva).

9.6 Manutenzione programmata



Utilizzare esclusivamente ricambi originali

Descrizione	Periodicità	Esecutore
Sostituzione tubo pompa peristaltica.	Annuale	Tecnici autorizzati
Controllo ventola asciugatura	Annuale	Tecnici autorizzati
Filtro vasca	Se necessario	Utilizzatore
Guarnizione tappo detergente	Se necessario	Utilizzatore
Guarnizione coperchio	Se necessario	Tecnici autorizzati

Le operazioni di **manutenzione e riparazione** devono essere effettuate con la macchina scollegata dall'alimentazione elettrica.

Una corretta manutenzione del dispositivo assicura un buon funzionamento della stessa e un sicuro risparmio in termini di tempo e costi dovuti ad assistenza.

10

SEGNALAZIONI - ERRORI

10.1 Segnalazioni



Display	Causa	Rimedio
	Il coperchio è aperto.	Chiudere il coperchio.
	Il liquido detergente nel serbatoio è insufficiente (≤ 0.5 l)	Rabboccare il serbatoio del detergente e riavviare il ciclo o impostare un ciclo senza detergente
	Il serbatoio detergente è pieno.	Interrompere il riempimento del serbatoio detergente. Se si continua il riempimento, il detergente uscirà dal tubo posteriore del troppopieno.

10.2 Errori

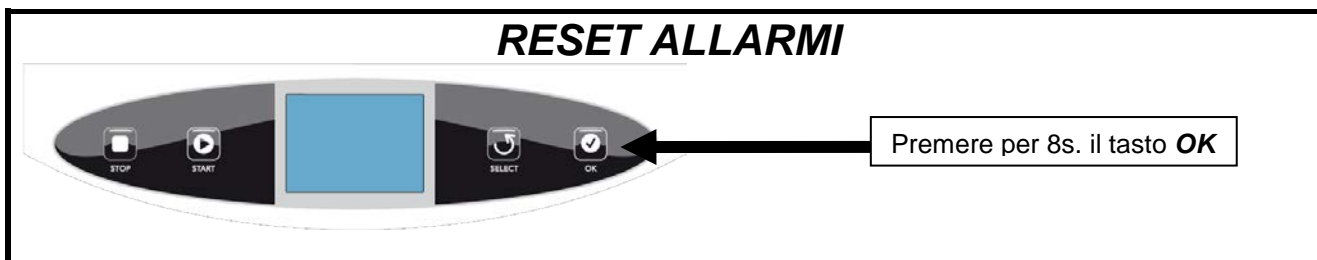
In caso di segnalazione di errore è necessario resettare il dispositivo per poter avviare un nuovo ciclo.

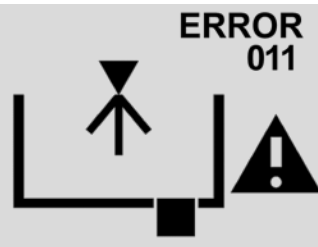

Display	Cause	Rimedi
<p>ERROR 005</p>	<p>Anomalia ingresso acqua</p> <ul style="list-style-type: none"> - Rubinetto chiuso - Filtro ingresso acqua ostruito - Anomalia nella pressione dell'impianto idrico 	<ul style="list-style-type: none"> - Controllare che il rubinetto sia aperto. - Pulire il filtro ingresso acqua. - Controllare che la pressione idrica sia nei limiti indicati. Se insufficiente consultare un idraulico per valutare i possibili rimedi. - Controllare che il Water Block non sia bloccato (OPZIONALE). - Verificare che non sia presente acqua in vasca e avviare un nuovo ciclo
<p>ERROR 010</p>	<p>Anomalia livello acqua</p> <ul style="list-style-type: none"> - Il dispositivo è stato spostato o inclinato durante il lavaggio. - Sono stati aggiunti molti strumenti dopo il caricamento acqua. 	<ul style="list-style-type: none"> - Verificare che non sia presente acqua in vasca e riavviare il ciclo. - Non aggiungere strumenti durante il ciclo.
<p>ERROR 008</p>	<p>Anomalia scarico acqua</p> <ul style="list-style-type: none"> - Filtri ostruiti. - Rottura pompa di scarico 	<ul style="list-style-type: none"> - Pulire filtro in vasca. - Verificare che non sia presente acqua in vasca e riavviare un ciclo.

Display	Cause	Rimedi
 <p>ERROR 011</p>	Anomalia ingresso acqua	<p>Pulire le SONDE J e Y (par 9.6)</p> <p>Pulire la parte in metallo con prodotti idonei per acciaio inox oppure un decapante. Utilizzare una spugna (leggermente abrasiva).</p>
 <p>ERROR 012</p>	<p>Anomalia ingresso acqua Anomalia nella pressione dell'impianto idrico</p>	<p>Pulire le SONDE J e Y (par 9.6)</p> <p>Pulire la parte in metallo con prodotti idonei per acciaio inox oppure un decapante. Utilizzare una spugna (leggermente abrasiva).</p> <p>Controllare che la pressione idrica sia nei limiti indicati. Se insufficiente consultare un idraulico per valutare i possibili rimedi.</p>

ELIMINAZIONE ACQUA IN VASCA
AVVIA LA POMPA DI SCARICO PER 30 SECONDI



10.4 Problemi generici

Problemi	Possibili cause	Rimedio
Pulizia scarsa	- Acqua calcarea, aloni bianchi presenti sugli strumenti	- Installare un addolcitore a monte. - Alcuni detergenti possono ridurre questo fenomeno
	- Presenza di elementi non pretrattati (cementi, alginati)	- Pretrattare con detergenti idonei.
	- Impostazioni del ciclo non corrette	- Variare i parametri, aumentando il tempo di lavaggio.
	- Non si percepisce il rumore degli ultrasuoni durante la fase di lavaggio	- Rivolgersi al servizio di assistenza tecnica
Asciugatura scarsa	- Eccessivo carico, presenza di gocce tra gli strumenti	- Ridurre il carico
	- Installazione non corretta, presenza di un velo di acqua sul fondo della vasca dopo lo scarico.	- Posizionare il dispositivo correttamente, modificare l'altezza dei piedi
	- Non si percepisce flusso d'aria dalle feritoie laterali del coperchio	- Rivolgersi al servizio di assistenza tecnica
Alcuni strumenti si danneggiano	- Strumenti non idonei al lavaggio ad ultrasuoni (es specchietti)	- Non lavare ad ultrasuoni strumenti non idonei

11 | PROCEDURE PER SERVIZIO ED ASSISTENZA

In caso di guasto o revisione contattare direttamente l'assistenza telefonica.

PHONE	+39 0521 8380
FAX	+39 0521 833391
@	service@tecnogaz.com

Sarà l'assistenza a valutare il rientro in sede o l'intervento di un tecnico e, visionata la macchina a stilare un preventivo di spesa, che verrà inoltrato al cliente distributore che lo trasmetterà al cliente finale, per presa d'atto e sottoscrizione.

Dopo aver ricevuto il preventivo sottoscritto per accettazione, il dispositivo verrà messo in lavorazione e verrà spedito nei tempi, indicati sul modulo del preventivo.

In caso si debba spedire il dispositivo in sede seguire le seguenti indicazioni obbligatorie:

- Utilizzare l'imballo originale, se questo non è più in Vostro possesso, utilizzare un imballo adeguato. La merce viaggia con rischio a carico del mittente.
- Spedire solo la vasca multifunzione (non inserire alcun componente contenuto nel kit accessori).
- Pulire accuratamente il dispositivo, prima di spedirlo. Nel caso giunga sporco e con residui, il dispositivo verrà rispedito non riparato, oppure verrà sottoposta ad azione di pulizia e disinfezione.
- Scaricare sempre il serbatoio del detergente.
- Indicare per iscritto, ed inserire nell'imballo un documento ove si indichi con precisione l'anomalia riscontrata o il servizio di cui si intende beneficiare.
- Spedire sempre in porto franco, diversamente saranno addebitate le spese di trasporto sostenute.

Tutti gli imballi non originali che ci perverranno, verranno smaltiti.

La macchina verrà rispedita con imballo originale (il costo dell'imballo vi sarà addebitato) mediante spedizioniere del cliente.

A	ACCESSORI	
	DESCRIZIONE	CODICE
	CESTELLO (180 mm X 280 mm H60 mm)	DVMA069
	GUARNIZIONI PIEDINI	DFAA493
	PORTAFRESE (D 70 mm H 60 mm)	DVMA072
	TUBO CARICO (L 3 mt)	CPLA002
	TUBO SCARICO (L 0.8-2.7 mt)	CPLA001
	CAVO ALIMENTAZIONE (L 2.5 mt)	CECG006
	IMBUTO	CPMG001
	WATER BLOCK (OPZIONALE)	DVMA092
	FILTRO VASCA	DVMA115
	PORTATRAY (OPZIONALE)	VM801ZVM
	N°1 TRAY (OPZIONALE)	SVMA070
	Multisteril CD Liquido detergente/disinfettante Diluizione per lavaggio ad ultrasuoni: 1% Contenuto 1 L Confezione 6 pz	DM401ALP

B **DISEGNI**

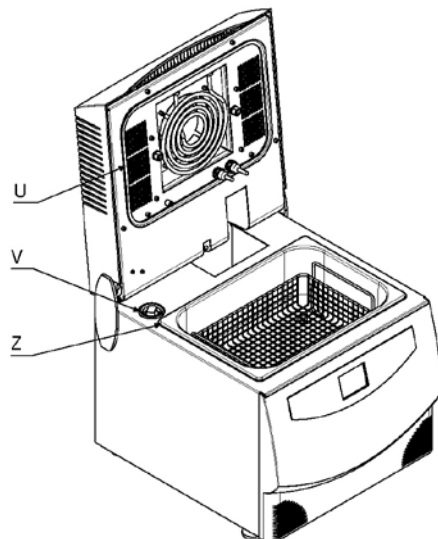
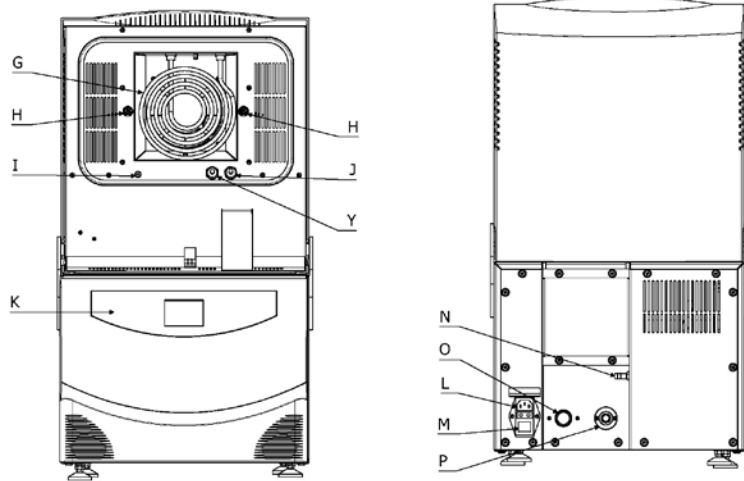
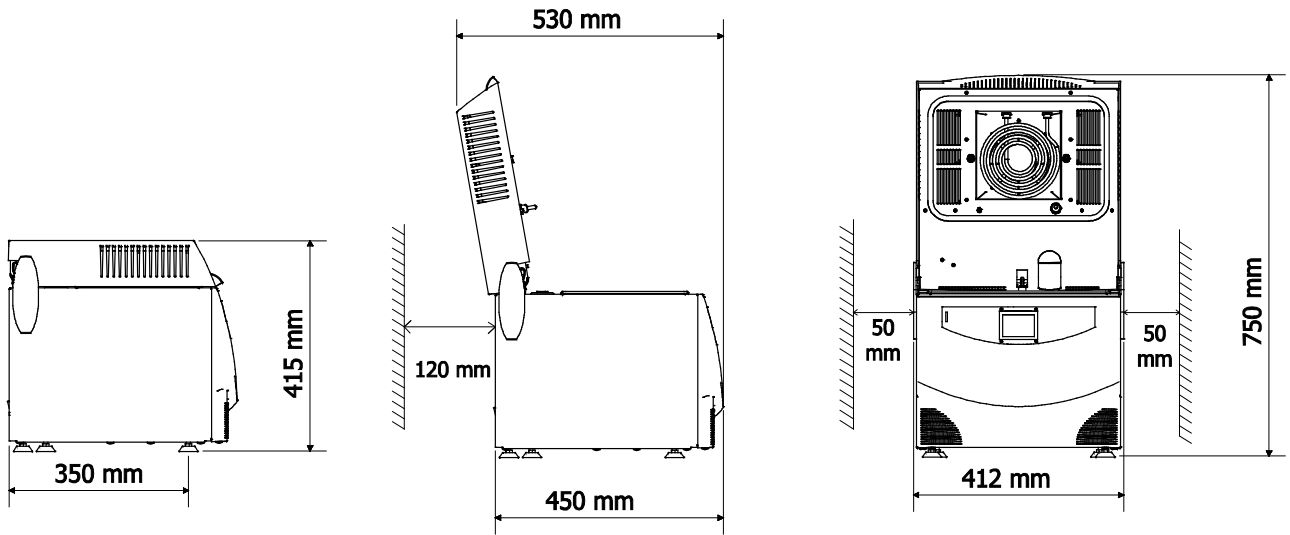

INDICE

- 1. UTILISATION AND INTENDED USE**
- 2. SAFETY**
 - 2.1 SAFETY MARKING
 - 2.2 SAFETY DEVICES
 - 2.3 DISPOSAL
- 3. TECHNICAL DATA**
- 4. UNPACKING**
- 5. COMPONENTS**
- 6. INSTALLATION**
 - 6.1 CONNECTIONS
 - 6.2 FILLING OF THE DETERGENT RESERVOIR
- 7. OPERATION OF THE APPLIANCE**
 - 7.1 CONTROL PANEL
 - 7.2 LANGUAGE SELECTION
 - 7.3 CYCLE SELECTION
 - 7.4 CYCLES STANDARD SETUP
 - 7.5 CYCLE CHANGES
 - 7.6 DELAYED START SETUP
- 8. USE INSTRUCTIONS**
- 9. MAINTENANCE**
 - 9.1 CLEANING
 - 9.2 TANK CLEANING
 - 9.3 TANK FILTER CLEANING
 - 9.4 WATER INFEEED FILTER CLEANING
 - 9.5 CLEANING THE LEVEL PROBE
 - 9.6 PLANNED MAINTENANCE
- 10. ERROR ALARMS**
 - 10.1 ALARMS
 - 10.2 ERRORS
 - 10.4 GENERAL PROBLEMS
- 11. PROCEDURES FOR AFTERSALE SERVICE**
 - A. ACCESSORIES**
 - B. DRAWINGS**

1 UTILISATION AND INTENDED USE

INTENDED USE	Multifunctional tank has been designed to remove organic and inorganic residue and dry instruments used in medical, dental, veterinary and beauty field.
---------------------	---

The appliance uses ultrasound cleaning to clean areas which cannot be easily reached through the manual clearing and without the risks caused by the handling of contaminated tools.

The appliance can store up to 3 cycles which can be set by the operator.

The main steps are:

CLEANING	This step reduces by more than 90% the microbial contamination. Such step removes the organic and inorganic residues.
RINSE	This step removes any residue of detergent from inside the tank.
DRYING	After the rinsing the appliance can be dried to remove water residues which might jeopardize the next sterilization cycle

	The multifunction tank shall be used <u>exclusively</u> to clean tools and materials compatible with the ultrasound cleaning system and in general for uses intended by the manufacturer.
---	--

2

SAFETY



The appliance shall never be used in potentially explosive atmospheres.



Place the appliance away from heat sources or electromagnetic radiation.



Place the tool so that the control panel and the display are clearly visible by the operator.



The electric system shall comply with the regulation in force, make sure the system suits the appliance characteristics.



Check for the power supply cord integrity.



Do not use flammable detergents



Do not inject acids (ex HCl) nor chlorides into the tank



Do not put any object in contact with the tank bottom



The manufacturer is responsible for the sold product pursuant to the regulation in force. Such responsibility voids in case some operations on the appliance or part of it are performed by unqualified staff or using non original spare parts.



DO NOT OPEN THE APPLIANCE.

In case of damage or risk of fluid infiltration into the appliance for the appliance maintenance or cleaning unplug the power cord.



Do not remove the plate



Before any intervention unplug the power cord from power socket.





Follow indications reported on the safety sheet of the used detergent.



In some cases ultrasounds can cause unpleasant noise. Wear suitable PPE.

2.1 Safety marking

	<p>DANGEROUS VOLTAGE</p>
 <p>ATTENZIONE ATTENTION ATTENTION ACHTUNG</p> <p>ALTA TEMPERATURA HIGH TEMPERATURES TEMPERATURES ELEVEES HOHE TEMPERATUR</p>	<p>HIGH TEMPERATURE</p>
	<p>EARTHING</p>

2.2 Safety devices

-) Door opening sensor
-) Safety thermostat
-) Water loading check system

2.3 Disposal



This product falls within directive 2002/96/EC of the European Parliament and of the Council of European Union on waste electric and electronic equipment (WEEE). For jurisdictions adopting such directive the product was launched in the market in a date following the 13 of August 2005 and shall not be disposed of as non recyclable household waste. Apply to specialized WEEE facilities for local collection for the disposal of this product or comply with the provisions in force.

3

TECHNICAL DATA

MECHANIC		
Working temperature	+5°C ÷ +30°C	
MAX relative humidity at 30°C	80%	
Overall dimensions (LxHxP)	415 x 415 x 530 mm	
Open lid height	750 mm	
Open lid depth	530 mm	
Weight (empty reservoir)	20 kg	
ELECTRIC		
Power voltage	230 V a.c. +/-10 % single phase	
MAX absorbed power	1 kW	
Frequency	50 / 60 Hz	
Power cord	2 + 1 x 1mm ²	
Fuses	6.3 A (5 x 20)	
ULTRASOUNDS		
N° of transducers	4	
Frequency	39 KHz	
WATER SUPPLY		
Water pressure	1.5 ÷ 2 Bar	
Conductivity of water	> 50 µS/cm	
MAX Temperature	+30°C	
Power hose dimension	3/8 G / length 3 m	
TANK		
Tank volume	9 l (S/S AISI 316)	
Water load volume	6 l	
DETERGENT RESERVOIR		
Volume	1.5 l + 0.5 l (reserve)	
Available cycles with full reservoir	Selected percentage	Available cycles*
	1%	≈25
	2%	≈12
	3%	≈8
	4%	≈6
	5%	≈5
	6%	≈4
Material	Polyethylene	
FILTERS		
Tank filter	S/S AISI 304	

The packing shall not undergo any shock and shall be handled with care avoiding letting it roll or fall.

The device is supported by a wooden pallet wrapped in corrugated cardboard and reinforced inside with cardboard pieces.

Open the corrugated cardboard, remove the reinforcement pieces and extract the appliance using exclusively the belts coming with the equipment.



The appliance shall be handled exclusively by means of the belts. Never lift the appliance by seizing it by the control panel. Such incorrect handling could damage the tool.



The packaging shall be stored for the whole warranty period. The manufacturer does not accept returns deprived of their original packing.



Do not use appliances with clear damages due to the transport.



Remove the packaging and check the appliance condition.

CONTENTS:

- **MULTI-FUNCTION TANK**
- **USE MANUAL:** to be carefully read and stored in a place accessible to all operators in charge of the device operation.
- **DECLARATION OF CONFORMITY :**to be stored.
- **INSTALLATION REPORT – TESTING AND WARRANTY CONDITIONS:** to be filled out upon appliance installation following indications reported on the form.
- **QUICK GUIDELINES FOR USE:** to be stored close to the appliance.
- Water supply hose
- Discharge hose
- Detergent drain hose
- Power cord
- Standard tray
- Dental burs tray
- Package of suggested detergent

05**DESCRIPTION OF COMPONENTS**

See Annex B – DRAWINGS

G	Drying resistance
H	Water nozzles
I	Detergent nozzle
J - Y	Probe
K	Keyboard and LCD
L	Main switch
M	Power plug with fuse holder
N	Detergent reservoir drain with overflow device
O	Water feeding (3/8 G)
P	Drain fitting
R	Gas spring
U	Lead gasket
V	Detergent manifold
Z	S/S tank

06

INSTALLATION



The appliance shall never be used in potentially explosive atmospheres.



Place the appliance away from heat sources or electromagnetic radiation.



Place the tool so that the control panel and the display are clearly visible by the operator.



The electric system shall comply with the regulation in force, make sure the system suits the appliance characteristics.

Open the lid and extract the accessories from the tank.

Position on a perfectly horizontal surface able to support loads of at least **35 kg**. The appliance supports are adjustable and allow for minor adjustment;



A wrong slope causes the deposit of a film of water on the tank bottom with associated drying problems

Position the appliance so as to allow the operator to easily inspect and clean the tank; the operator shall have access to the appliance rear panel for the filter cleaning.

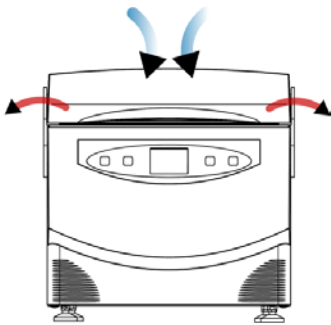

For the drying phase air is taken from the rear side and hot air is discharged from the device sides.

Let at least 50 mm clearance on both sides.

6.1 Connections

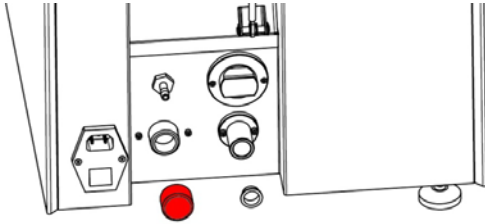

Remove safety caps.

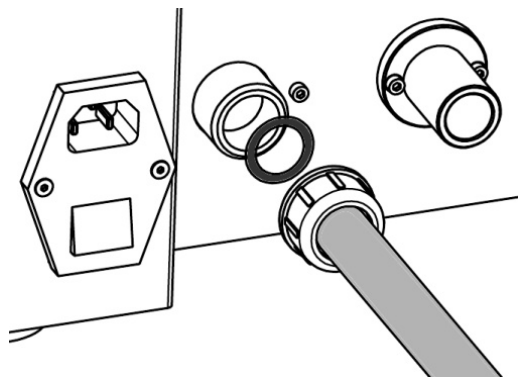

Water feeding hose.

Connect the hose to the appliance (O) fitting also the rubber gasket. Connect the other side to the feeding cock.

OPTIONAL: emergency water block system (WATER BLOCK). Such device shall be vertically mounted immediately downstream the feeding cock. See the device instructions for further information on the tool installation and use.

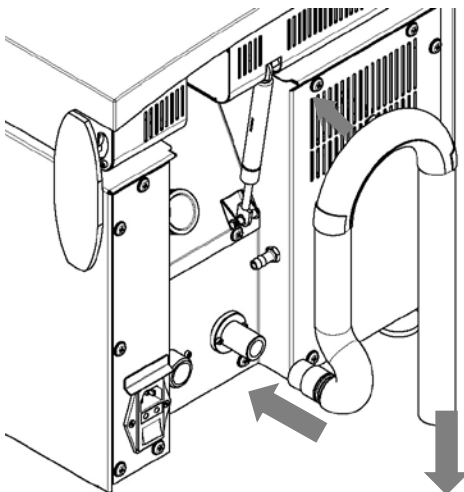

Water drain hose.

Remove the safety cap. Connect the hose to the device (P). Connect the other end to the discharge. Fix it safely and securely.



Install the siphon as shown in the figure

Detergent reservoir drain hose

Take the transparent drain hose to a visible point at the same height of the appliance leaning plane or under it. Do not obstruct nor keep it immersed into the fluid. The drain hose has also an overflow function, when the detergent reservoir is full, if some more detergent is injected the drain hose discharges it.

Power cord



Check the integrity of the power cord.

Connect the power cord to the socket on the rear side of the appliance (M).



Do not use extensions, reductions or adapters for connection

Switch on the device through the switch (L).

Open the water feeding cock and make sure the feeding hose has no leak (if leaks are present, clamp couplers and make sure gaskets are fitted). Make sure the tank filter is present and that it is clean.

6.2 Filling of the detergent reservoir:

The tank has a capacity of about 2 l , 0.5 of which as reserve.
During the filling the device has to be ON and display 'CYCLE SELECTION.



ALWAYS SWITCH ON THE DEVICE BEFORE FILLING THE DETERGENT TANK

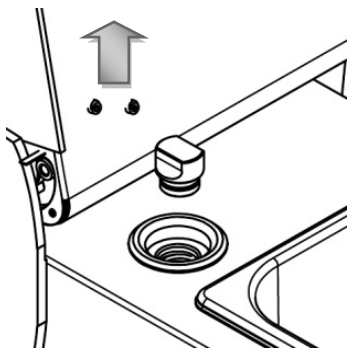

Open the tank lid and lift the cap (V) on the left side of the tank.

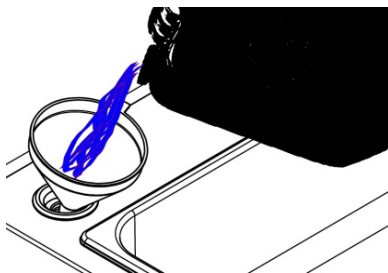

Feed the detergent (use the funnel coming with the appliance) until and acoustic/visual signal (on the display) warns that the reservoir is full



Use exclusively fluids recommended by the manufacturer.



Do not mix fluids inside the reservoir since deriving chemical reactions can cause relevant damages to the device.

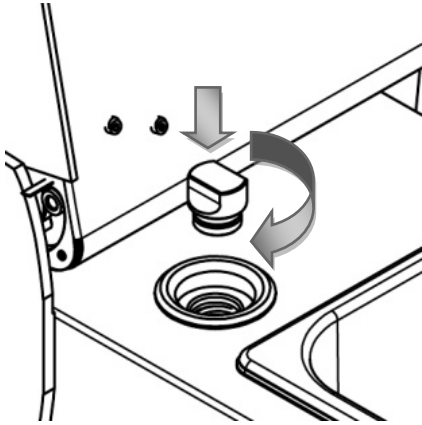

Slightly press and rotate to close the detergent feeding cap.



Close the detergent feeding cap to avoid detergent crystallization which could cause obstructions of and damages to some components.



7 OPERATION OF THE APPLIANCE





The multifunctional appliance has a lifting lid to allow access to the washing tank.

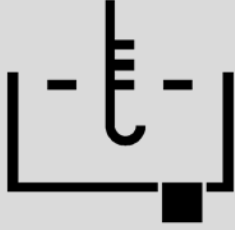

The tray, equipped with rubber supports and filled with items to be cleaned, has to be positioned inside the tank.

The multifunctional appliance has an internal reservoir suitable to hold a detergent which is dosed and injected automatically into the washing tank during the cycle.

A complete washing cycle includes the following steps.

PHASE	SYMBOL	DESCRIPTION	TIME																																			
1		<p>Water loading</p> <p>Water enters the tank until exceeding the tray edge by approx 2 mm. The total volume is of approx 6 l.</p>	<p>1.5 min (P infeed = 2.5 bar)</p>																																			
2		<p>Detergent loading</p> <p>A pump doses automatically and transfers the preset amount of detergent from the internal reservoir to the tank:</p> <table border="1" data-bbox="539 1276 1133 1780"> <thead> <tr> <th>Selected percentage</th> <th>Volume (ml)</th> <th>Available cycles*</th> </tr> </thead> <tbody> <tr> <td>1%</td> <td>60</td> <td>≈25</td> </tr> <tr> <td>2%</td> <td>120</td> <td>≈12</td> </tr> <tr> <td>3%</td> <td>180</td> <td>≈8</td> </tr> <tr> <td>4%</td> <td>240</td> <td>≈6</td> </tr> <tr> <td>5%</td> <td>300</td> <td>≈5</td> </tr> <tr> <td>6%</td> <td>360</td> <td>≈4</td> </tr> </tbody> </table> <p><i>*With full reservoir (1500 ml)</i></p>	Selected percentage	Volume (ml)	Available cycles*	1%	60	≈25	2%	120	≈12	3%	180	≈8	4%	240	≈6	5%	300	≈5	6%	360	≈4	<table border="1" data-bbox="1236 1276 1380 1780"> <thead> <tr> <th>%</th> <th>sec</th> </tr> </thead> <tbody> <tr> <td>1</td> <td>80</td> </tr> <tr> <td>2</td> <td>160</td> </tr> <tr> <td>3</td> <td>240</td> </tr> <tr> <td>4</td> <td>320</td> </tr> <tr> <td>5</td> <td>400</td> </tr> <tr> <td>6</td> <td>480</td> </tr> </tbody> </table>	%	sec	1	80	2	160	3	240	4	320	5	400	6	480
Selected percentage	Volume (ml)	Available cycles*																																				
1%	60	≈25																																				
2%	120	≈12																																				
3%	180	≈8																																				
4%	240	≈6																																				
5%	300	≈5																																				
6%	360	≈4																																				
%	sec																																					
1	80																																					
2	160																																					
3	240																																					
4	320																																					
5	400																																					
6	480																																					

<p>3</p>		<p>Heating The device performs a heating phase lasting 5 minutes and a first decontamination of tools. If temperature is not achieved, heating continues also during the washing phase.</p>	<p>5 min¹</p>
<p>4</p>	 <p>LAMPEGGIANTE</p>	<p>Degas (DEGAS) The device activates intermittent ultrasounds for 5 minutes. This process reduces gases in the fluid and improves effectiveness of the next cleaning phase.</p>	<p>5 min¹</p>
<p>4S</p>	<p>PRESS START TO CONTINUE</p>	<p>STANDBY This new phase allows operating important process as: - Keeps the instruments in the washing liquid (SOAKING) - Add instruments (ATTENTION: STEEL MAX 1 KG.) TO EXIT THE STANDBY PHASE AND END AUTOMATICALLY THE CYCLE IS NECESSARY TO PRESS START.</p>	
<p>5</p>		<p>Ultrasound cleaning Cleaning phase by means of ultrasonic cavitation.</p> <p>SWEEP Ultrasounds undergo frequency modulation thus reducing the negative effects of stationary waves and increasing distribution of ultrasonic energy into the cleaning fluid. Cleaning is more effective (cavitation is improved)</p>	<p>1 min to 30 min</p>
<p>6</p>		<p>Draining The tank drains automatically</p>	<p>≈ 1.5 min</p>

7		<p>Second water loading</p> <p>The tank is filled again to rinse tools</p>	<p>1.5 min (P infeed = 2.5 bar)</p>
8		<p>Ultrasound rinse</p> <p>Short activation of ultrasounds, rinse by cavitation.</p>	<p>1 min</p>
9		<p>Draining</p> <p>The tank drains automatically</p>	<p>≈ 1.5 min</p>
10		<p>Drying</p> <p>To dry tools, the appliance generates a hot air flow touching items and removing humidity as vapour.</p>	<p>15 min</p>

Notes:

1 Heating and degas phases, if they are both preset, are carried out simultaneously for a total time of 5 minutes.

7.1 Control panel

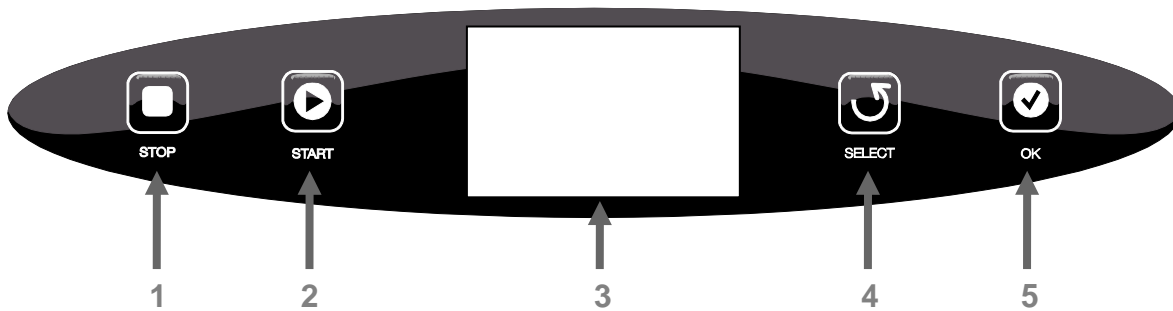

CYCLE START/STOP KEYS

1	STOP – IT STOPS THE CURRENT CYCLE
2	START – START CYCLE

PROGRAMMING KEYS

4	SELECT – NAVIGATION BUTTON
5	OK – CONFIRM SELECTION AND GO TO THE NEXT SECTION
3	DISPLAY

7.2 Language selection

Press **STOP** for 8 seconds.

The display shows the preset language.

Press **SELECT** to scroll available languages.

Press **OK** to confirm the selected language.

7.3 Cycle selection

Upon the appliance switch ON the manufacturer's logo is displayed together with the firmware version.

After 3 seconds have elapsed the display shows:

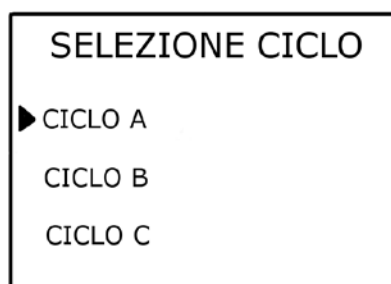

Press **SELECT** to scroll programs.

Press **START** to start the selected cycle.

7.4 Cycles standard setup

The appliance comes with the following default parameters:

	A	B	C
Standby	ON	OFF	OFF
Detergent infeed	1 %	1 %	1 %
Heating	ON	OFF	ON
Degas function	SI	SI	SI
SWEEP function	NO	SI	NO
Ultrasound cleaning	20 min	20 min	5 min
Drying	SI	SI	SI

Parameters can be modified for all cycles.

7.5 Cycle changes

Select the cycle to be modified.
 Press **OK** to display the MENU.
 Available parameters:

Description	Parameters	Step
Standby	ON - OFF	-
Detergent infeed	0 ÷ 6 %	1%
Heating	ON - OFF	-
Degas function	SI - NO	-
SWEEP function	SI - NO	-
Ultrasound cleaning	0 ÷ 30 min	1 min
Drying	SI - NO	-

Press **OK** to scroll the cycle parameters.
 Press **SELECT** to modify the value of the selected parameter.
The menu of the parameters and setup scrolls circularly.
 Once the setup is completed select EXIT and press **SELECT** to quit the MENU.
Changes are saved.

7.6 DELAYED START setup:

Hold down **START** for 8 seconds.
 Press **SELECT** to scroll values from 1 to 9 hours.
 Press **START** to start the delayed start.
 During the waiting time a timer is displayed showing the time remaining before the cycle start.
WARNING: In case voltage is missing the delayed start is cancelled.

8 USE INSTRUCTIONS

Open the water feeding cock. Check the presence of the filter in the tank and make sure it is clean. Position the item to be cleaned into the TRAY in case of small parts use the DENTAL BURS TRAY.

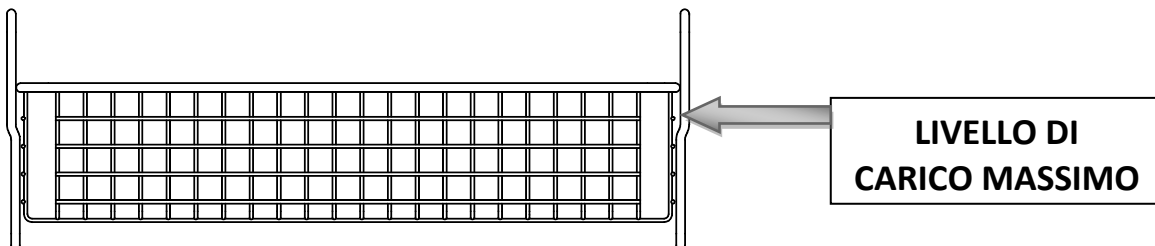

Items to be cleaned have to be distributed uniformly and must not touch the tank walls or bottom.
Fit the tray inside the tank, be sure there is no contact between the tank walls and the tray.

Cements, alginates, and composites must be treated with specific fluids.

In case of rough dirt on the items, such dirt has to be removed before loading the tools inside the tray to avoid the drain filter obstruction.

To prevent contact between the steel tray feet and the steel cleaning tank rubber rings are used. In case rings are missing or damaged replace them with new ones. The wrong use can cause damages to the tank. Switch on the machine through the switch (L).

Start the selected cycle pressing **START** the appliance shows the current cycle phase and the countdown of the time (estimated time) necessary to complete the cycle.

If the cycle provides STANDBY phase you will have to press **START** a second time (after the loading water, detergent input, degas and heating phases) to go to the washing step and finish the whole cycle.

At the end of the cycle the message 'END CYCLE OK' is displayed accompanied by an acoustic alarm. Press OK to go to the cycle selection.

If the door is opened while the device is ON, the current process is immediately stopped.

When the lid is closed the cycle will restart exactly from the point it has been interrupted.



At the end of the day close the cock mounted upstream the device.



Do not touch items, the lid or the resistance during drying. Risk of burns.



Drain the reservoir completely before injecting a detergent different from the one previously held

Use of detergent other than that contained into the reservoir:

Detergent other than that contained in the reservoir can be used.

In the menu of the cycle to be performed enter 'NO' as reference to the detergent automatic infeed.

Start the cycle, after some minutes (at the end of the water drain phase) the device sends out an acoustic signal, it is now possible to open the lid and inject into the tank the correct detergent percentage (1% - 60ml).

Close the lid to complete the cycle.

Detergent reservoir draining:

During the appliance use, when injection of detergent is required, in order to drain completely the detergent reservoir, press and hold down button **SELECT** and at the same time hold down button **OK**.

After 5 seconds the peristaltic pump starts, during this phase an intermittent acoustic signal is sent out which stops only when the phase is over, the detergent is drained directly into the tank through the nozzle on the lid (I).

After about 10 min slightly open the lid (without letting the lid opening sensor intervene) and make sure no detergent comes out of the nozzle.

Once the draining is completed, stop the process using button **STOP**.

9

MAINTENANCE

9.1 Cleaning

The cleaning shall be carried out after the cooling of the device and the unplugging of the power cord.



Use non aggressive detergents suitable for plastics



Use detergents suitable for s/s steel

9.2 Tank cleaning



Check the cleaning of the tank at the end of each cycle

Remove deposits or debris to avoid injection of materials into the drain circuit and cause obstruction.

9.3 Tank filter cleaning



Check the cleaning of the tank filter at the end of each cycle

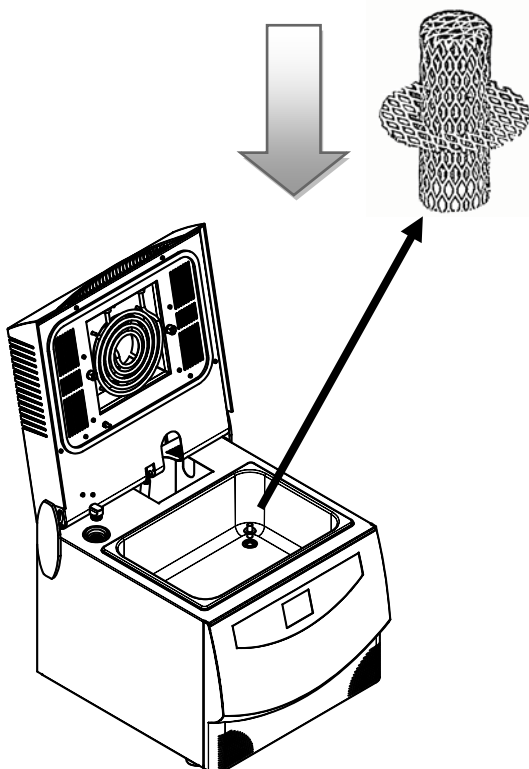

Lift the device lid;

Remove residues from the tank.

Extract the metal filter in the tank and pull it upward, as shown in the picture;

Wash the filter under tap water to remove impurities.

Re-place the filter in its position: the filter open side has to be inside the drain coupler while the close one has to be seen from inside the tank.

9.4 Cleaning of the water infeed filter

To be checked periodically

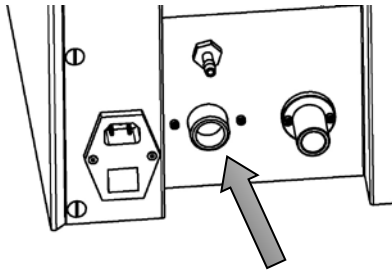

Close water supply, remove the water feeding hose and make sure the filter (O) is clean.

On the contrary extract it using pliers without forcing and wash with water.

Remount the filter and the feeding hose.

9.5 Cleaning the level probe

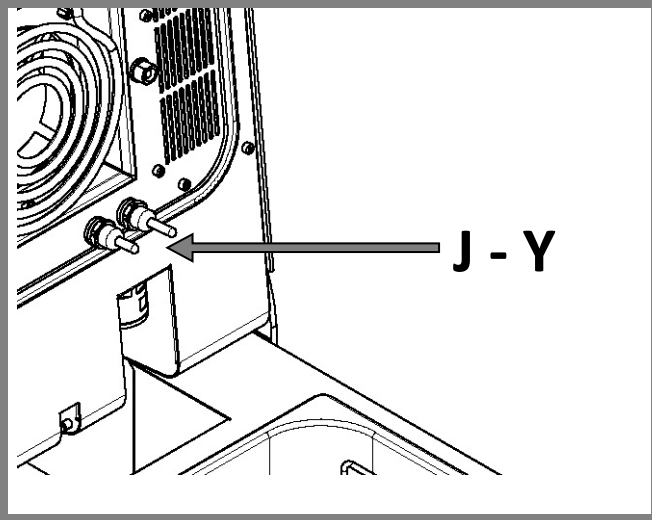

Check periodically (every 2-3 cycles) the **PROBE J - Y**

Clean the metal with products suitable for stainless steel or a stripper.

Use a sponge (slightly abrasive).

9.6 Planned maintenance



Use exclusively original spare parts

Description	Interval	Operator
Replacement of the peristaltic pump hose.	Yearly	Authorized technicians
Drying fan check	Yearly	Authorized technicians
Tank filter	Whenever necessary	User
Detergent cap gasket	Whenever necessary	User
Lid gasket	Whenever necessary	Authorized technicians



Maintenance and repair operations shall be carried out after unplugging the machine from power supply.

A correct maintenance of the device ensures its correct functioning as well as time and service cost saving.

10

ERROR ALARMS

10.1 Alarms

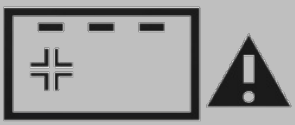

Display	Cause	Solution
	The lid is open.	Close the lid.
	Insufficient amount of detergent inside the reservoir (≤ 0.5 l)	Refill the detergent reservoir and restart the cycle or set a cycle without detergent
	Detergent reservoir full.	Stop the filling of the detergent reservoir. If filling goes on detergent will come out from the rear overflow hose.

10.2 Errors

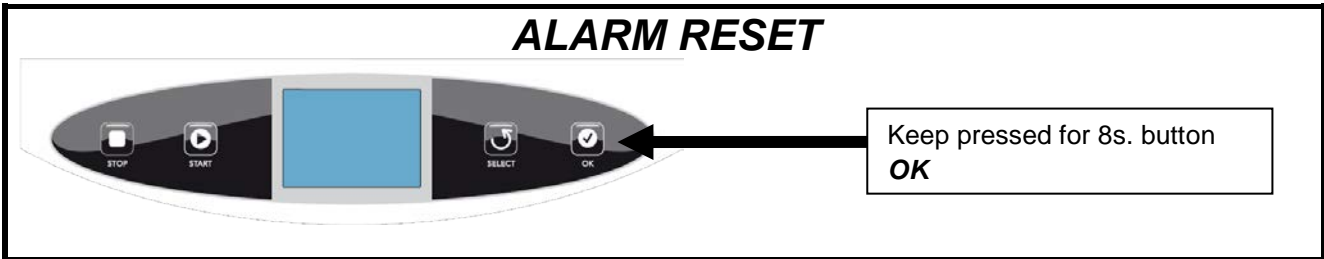
In case of error alarm the device has to be reset to start a new cycle.

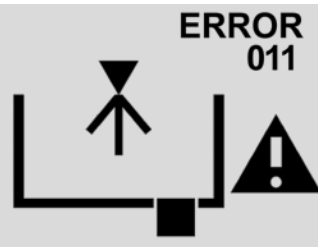

Display	Cause	Solution
<p>ERROR 005</p>	<p>Water infeed alarm</p> <ul style="list-style-type: none"> - the tap is closed - filters clogged - pressure of the water system not normal 	<ul style="list-style-type: none"> - Make sure the tap is open. - Clean water infeed filter. - Make sure water pressure ranges are within the indicated values. If the pressure is insufficient, contact a plumber. - Make sure the Water Block (OPTIONAL) is not locked. - Make sure there is no water into the tank and start a new cycle
<p>ERROR 010</p>	<p>Water level alarm</p> <ul style="list-style-type: none"> - the device has been moved or tilted during the cleaning. - too many instruments have been added after water infeed. 	<ul style="list-style-type: none"> - Make sure there is no water into the tank and start a new cycle. - Do not add instruments during the cycle.
<p>ERROR 008</p>	<p>Water drain alarm</p> <ul style="list-style-type: none"> - filters clogged - Discharge pump breakage 	<ul style="list-style-type: none"> - Clean the tank filter. - Make sure there is no water into the tank and start a new cycle.

Display	Causes	Solutions
 <p>ERROR 011</p>	<p>Water infeed alarm</p>	<p>PROBE J - Y Clean the metal with products suitable for stainless steel or a stripper. Use a sponge (slightly abrasive).</p>
 <p>ERROR 012</p>	<p>Water infeed alarm Pressure of the water system not normal</p>	<p>PROBE J - Y Clean the metal with products suitable for stainless steel or a stripper. Use a sponge (slightly abrasive). Make sure water pressure ranges are within the indicated values. If the pressure is insufficient, contact a plumber.</p>

TANK WATER DISCHARGE

IT STARTS THE DISCHARGE PUMP FOR 30 SECONDS

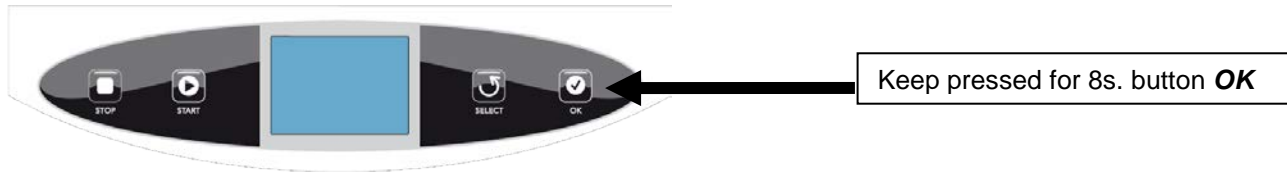

10.4 General problems

Problems	Possible causes	Solution
Poor cleaning	- Calcareous water, white halos on the tools	- Install a water softener before the device. - Some detergents might reduce such effect
	- Traces of elements which have not been pre-treated (cements, alginates)	- Pre-treat with suitable detergents.
	- Wrong cycle parameters	- Modify parameters increasing the cleaning time .
	- The ultrasound noise is not heard during the cleaning phase	- Contact the technical service
Poor drying	- Load excessive, drops on tools	- Reduce the load
	- Wrong installation, rests of water on the tank bottom after the draining.	- Position the device correctly, modify the height of the feet
	- No air flow from the lid side slots	- Contact the technical service
Some instruments get damaged	- Instruments that cannot be treated with ultrasounds cleaning (e.g. Mirrors)	- Do not clean with ultrasounds instruments that cannot be treated with ultrasounds treatment

In case of damage or for overhaul contact directly the phone service.

PHONE	+39 0521 8380
FAX	+39 0521 833391
@	service@tecnogaz.com

The service staff shall decide whether the return to the manufacturer or the intervention of a technician is necessary; after checking the device the service staff will draw up a quote to be submitted to the distributor which, on its turn, will submit it to the final customer for subscription.

Upon reception of the subscribed quote the device will be repaired and then shipped back within the times indicated on the quote form.

In case of shipment of the device to the manufacturer follow the compulsory indications below:

- Use the original packaging, in case you do not have it anymore, use a suitable packaging. The goods shipment risk is charged to the sender.
- Ship only the multifunction tank (do not introduce any other component of the accessories kit).
- Carefully clean the whole tank before shipping it. If the received device is dirty or has residues the tank shall be shipped back without having been repaired or will be cleaned or disinfected.
- Always drain detergent from the reservoir.
- Write down and include into the package a document describing accurately the anomaly or the service required.
- Free port shipment is required, otherwise the supported transport costs will be charged.

All non original packages we will receive shall be disposed of.

The machine will be shipped back in its original packaging (the cost for the packaging will be charged to you) through the customer's forwarder.

A**ACCESSORIES**

	DESCRIPTION	CODE
	TRAY (180 mm X 280 mm H60 mm)	DVMA069
	FEET GASKET	DFAA493
	DENTAL BURS TRAY (D 70 mm H 60 mm)	DVMA072
	FEEDING HOSE (L 3 mt)	CPLA002
	DRAINING HOSE (L 0.8-2.7 mt)	CPLA001
	POWER CORD (L 2.5 mt)	CECG006
	FUNNEL	CPMG001
	WATER BLOCK (OPTIONAL)	DVMA092
	TANK FILTER	DVMA115
	TRAY HOLDER (OPTIONAL)	VM801ZVM
	N°1 TRAY (OPTIONAL)	SVMA070
	LIQUID DETERGENT/DISINFECTANT DILUTION PERCENTAGE FOR ULTRASONIC WASH: 1% 1,0 L BOTTLE 6 BOTTLES PACK	DM401ALP

B **DRAWINGS**

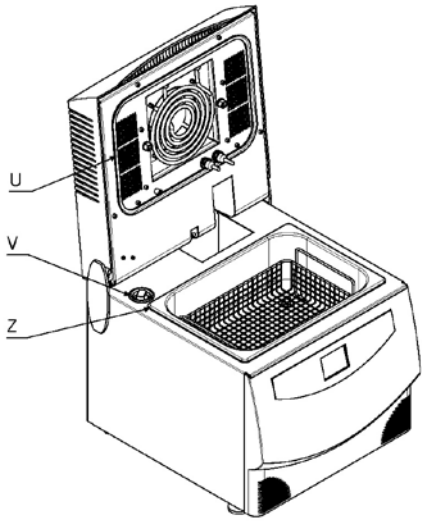
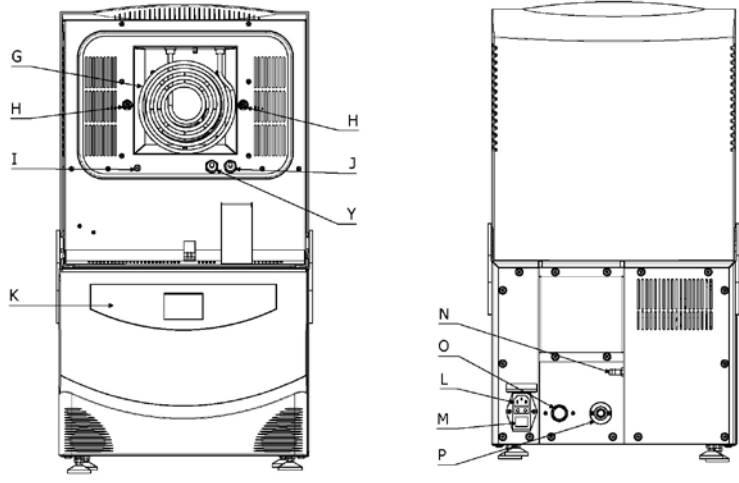
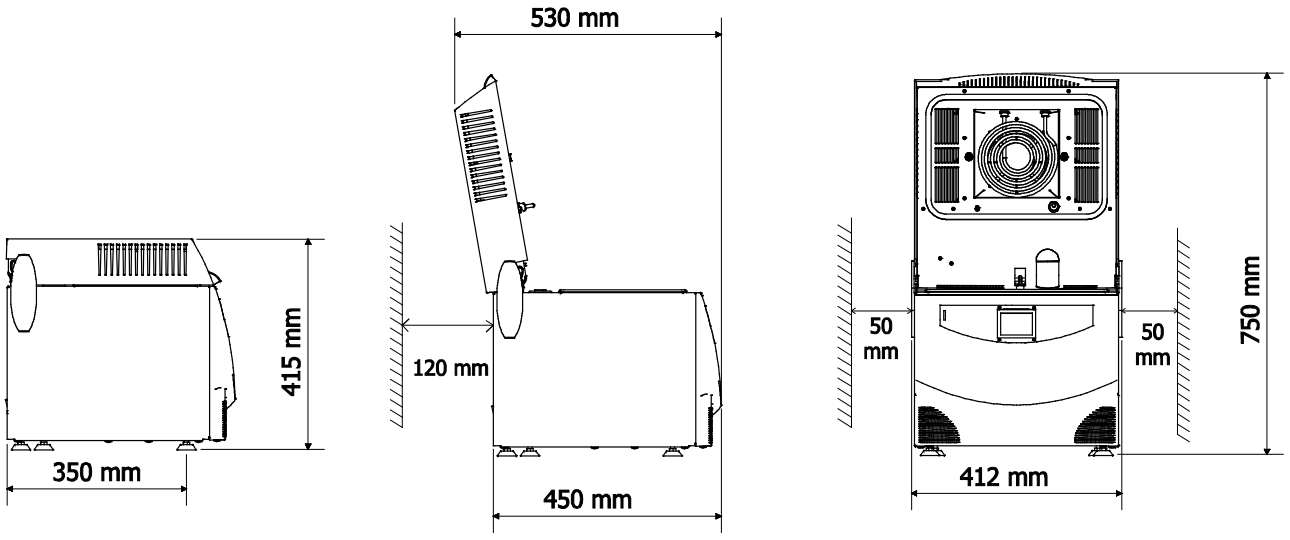

TABLE DES MATIERES

- 1. UTILISATION ET USAGE PREVU**
- 2. SECURITE**
 - 2.1 MARQUAGE DE SECURITE
 - 2.2 DISPOSITIFS DE SECURITE
 - 2.3 ECOULEMENT
- 3. DONNES TECHNIQUES**
- 4. DESEMBALLAGE**
- 5. COMPOSANTS**
- 6. INSTALLATION**
 - 6.1 CONNEXIONS
 - 6.2 REMPLISSAGE RESERVOIR DETERGENT
- 7. FONCTIONNEMENT DE L'APPAREIL**
 - 7.1 TABLEAU DES COMMANDES
 - 7.2 SELECTION LANGUE
 - 7.3 SELECTION CYCLE
 - 7.4 CONFIGURATION STANDARD DES CYCLES
 - 7.5 MODIFICATIONS DES CYCLES
 - 7.6 CONFIGURATION DEMARRAGE RETARDE
- 8. MODE D'EMPLOI**
- 9. ENTRETIEN**
 - 9.1 NETTOYAGE
 - 9.2 NETTOYAGE DE LA CUVE
 - 9.3 NETTOYAGE DU FILTRE DE LA CUVE
 - 9.4 NETTOYAGE DU FILTRE D'ENTREE DE L'EAU
 - 9.5 NETTOYAGE DE LA SONDE DE NIVEAU
 - 9.6 ENTRETIEN PROGRAMME
- 10. SIGNALISATIONS – ERREURS**
 - 10.1 SIGNALISATIONS
 - 10.2 ERREURS
 - 10.4 PROBLEMES GENERIQUES
- 11. PROCEDURES POUR LE SERVICE ET L'ASSISTANCE**
 - A. ACCESSOIRES**
 - B. DESSINS**

1

UTILISATION ET USAGE PREVU

USAGE
PREVU

La cuve multifonction a été projeté pour éloigner les restes organiques et inorganiques et pour sécher les instruments utilisés dans le secteur médical, dental, esthétique et vétérinaire

Le dispositif, par le biais d'une déterSION par ultrasons, permet de nettoyer des endroits difficiles à atteindre par un nettoyage à la main et sans les risques causés par la manipulation des instruments souillés et contaminés.

Le dispositif peut mémoriser 3 cycles qui peuvent être programmés par l'utilisateur.

Les phases principales sont les suivantes:

DECONTAMINATION	Phase qui réduit de plus de 90% le niveau de la contamination microbienne. Cette phase élimine la matière organique et inorganiques résiduelle.
RINCAGE	Cette phase élimine les résidus éventuels de détergeant présents dans la cuve.
SECHAGE	Après le rinçage les instruments doivent être rincés afin d'éviter que d'éventuels résidus d'eau puissent compromettre le processus de stérilisation successif.



La cuve multifonction doit être utilisée exclusivement pour la décontamination d'instruments et matériel compatibles avec le système de nettoyage à ultrasons et, en général, uniquement pour les usages prévus par le constructeur.

2

SECURITE



L'appareil ne doit être utilisé dans les atmosphères potentiellement explosives.



Positionner l'appareil loin de sources de chaleur ou de radiations électromagnétiques.



Positionner l'appareil de façon que le tableau de commandes et l'écran soient clairement visibles pour l'opérateur.



L'installation électrique doit être conforme à la normative en vigueur; s'assurer que l'installation électrique soit adéquate aux caractéristiques du dispositif.



Vérifier l'intégrité du câble d'alimentation.



Ne pas utiliser des détergents inflammables



Ne pas introduire des acides (ex. HCl) ni des chlorures dans la cuve



Ne pas introduire des objets en le mettant en contact avec le fond de la cuve



Le constructeur sera tenu responsable du produit introduit sur le marché aux sens de la réglementation en vigueur. La responsabilité échoit lorsque les opérations sont accomplies sur le dispositif, ou sur des parties de celui-ci, de la part de personnel non qualifié ou à l'aide de pièces de rechange non d'origine.



NE PAS OUVRIR L'APPAREIL.

En cas de défaillances ou de risque d'infiltration de liquide dans l'appareil, en cas d'entretien et nettoyage de l'appareil, débrancher le câble d'alimentation électrique.



Ne pas enlever la plaquette des données



Avant n'importe quelle intervention, débrancher le câble d'alimentation de la prise de courant.





S'en tenir aux indications spécifiées sur la fiche de sécurité du liquide détergent utilisé.



Les ultrasons en certaines conditions peuvent produire des bruits agaçants pour les oreilles. Mettre donc des EPI adaptés.

2.1 Marquage de sécurité

	<p>TENSION DANGEREUSE</p>
 <p>ATTENZIONE ATTENTION ATTENTION ACHTUNG</p> <p>ALTA TEMPERATURA HIGH TEMPERATURES TEMPERATURES ELEVÉES HOHE TEMPERATUR</p>	<p>HAUTE TEMPERATURE</p>
	<p>CONNEXION A LA TERRE</p>

2.2 Dispositifs de sécurité

-) Capteur ouverture porte
-) Thermostat de sécurité
-) Système de contrôle charge eau

2.3 Ecoulement



Ce produit doit se conformer à la directive 2002/96/EC du Parlement Européen et du Conseil de l'Union Européenne sur les déchets d'équipements électriques et électroniques (DEEE). Dans les juridictions adoptant cette directive, le produit a été lancé sur le marché en date successive au 13 Août 2005 et ne doit pas être écoulé en tant que déchet ménager non recyclable. Utiliser les structures DEEE locales consacrées à l'écoulement de ce produit ou bien s'en tenir aux dispositions en vigueur.

3

DONNEES TECHNIQUES**MECANIQUES**

Température de fonctionnement	+5°C ÷ +30°C
Humidité relative MAX à 30°C	80%
Dimensions encombrement (LxHxP)	415 x 415 x 530 mm
Hauteur couvercle ouvert	750 mm
Profondeur couvercle ouvert	530 mm
Poids (réservoir vides)	20 kg

ELECTRIQUES

Tension alimentation	230 V c.a. +/-10 % monophasé
Puissance MAXI absorbée	1 kW
Fréquence	50 / 60 Hz
Câble d'alimentation	2 + 1 x 1mm ²
Fusibles	6.3 A (5 x 20)

ULTRASONS

N° transducteurs	4
Fréquence	39 KHz

ALIMENTATION EN EAU

Pression eau	1.5 ÷ 2 Bar
Conductivité de l'eau	> 50 µS/cm
Température MAX	+30°C
Dimensions tuyau alimentation	3/8 G / 3 m de long

CUVE

Volume cuve	9 l (Acier inox AISI 316)
Volume charge eau	6 l

RESERVOIR DETERGENT

Volume	1.5 l + 0.5 l (réserve)
--------	---------------------------

Cycles exécutables avec le réservoir plein	Pourcentage sélectionné	Cycles exécutables *
	1%	≈25
2%	≈12	
3%	≈8	
4%	≈6	
5%	≈5	
6%	≈4	

Matériau	Polyéthylène
----------	--------------

FILTRES

Filtre cuve	Acier inox AISI 304
-------------	---------------------

L'emballage ne doit pas subir de chocs et doit être manipulé avec soin en évitant de le faire rouler ou tomber.

Le dispositif est soutenu par une palette en bois et renfermé dans un carton ondulé et renforcé à l'intérieur par des pièces composées de carton.

Ouvrir le carton ondulé, enlever les pièces de renfort et extraire le dispositif exclusivement à l'aide des courroies fournies.



La manutention de l'appareil doit se faire exclusivement à l'aide des courroies en dotation. Ne jamais soulever le dispositif en le prenant par le tableau des commandes.

Cette opération pourrait en effet endommager l'appareillage.



L'emballage doit être préservé pendant toute la période de garantie.

Le constructeur n'accepte pas que le dispositif soit rendu sans emballage d'origine.



Ne pas utiliser d'appareillages qui présentent des dommages évidents découlant du transport.



Enlever l'emballage et contrôler l'état de l'appareil.

CONTENU:

- **CUVE MULTIFONCTION**
- **MANUEL D'UTILISATION:** A lire soigneusement et à ranger dans un endroit accessible à tous les opérateurs responsables du fonctionnement du dispositif.
- **DECLARATION DE CONFORMITE:** à conserver.
- **RAPPORT D'INSTALLATION – ESSAI FINAL ET CONDITIONS DE GARANTIE:** A remplir lors de l'installation de la machine suivant les indications spécifiées dans le formulaire.
- **GUIDE RAPIDE A L'UTILISATION:** A garder près de la machine.
- Tuyau d'alimentation eau
- Tuyau de décharge
- Tuyau de purge détergent
- Câble d'alimentation
- Panier standard
- Panier porte-fraises
- Flacon détergent conseillé

05**DESCRIPTION DES COMPOSANTS**

Se référer à l'Appendice B – DESSINS

G	Résistance séchage
H	Buses eau
I	Buses détergent
J - Y	Sonde
K	Clavier et LCD
L	Interrupteur général
M	Prise d'alimentation avec porte-fusibles
N	Purge réservoir détergent avec fonction de trop-plein
O	Entrée eau (3/8 G)
P	Raccord tuyau de décharge
R	Ressort à gaz
U	joint couvercle
V	Collecteur détergent
Z	Cuve inox



L'appareil ne doit pas être utilisé dans les atmosphères potentiellement explosives.



Positionner l'appareil loin de sources de chaleur ou de radiations électromagnétiques.



Positionner l'appareil de façon que le tableau de commandes et l'écran soient clairement visibles pour l'opérateur.



L'installation électrique doit être conforme à la normative en vigueur; s'assurer que l'installation électrique soit adéquate aux caractéristiques du dispositif.

Ouvrir le couvercle et extraire les accessoires contenus dans la cuve.

Positionner sur une surface parfaitement horizontale, stable et résistante à des charges d'au moins **35 kg**. Les supports du dispositif sont réglables et permettent des ajustements minimums;



Suite à une pente erronée un film d'eau pourrait rester sur le fond de la cuve en causant des problèmes de séchage

Positionner le dispositif de manière à permettre à l'opérateur d'inspecter et nettoyer aisément la cuve; l'opérateur doit pouvoir accéder à l'arrière du dispositif pour le nettoyage du filtre.

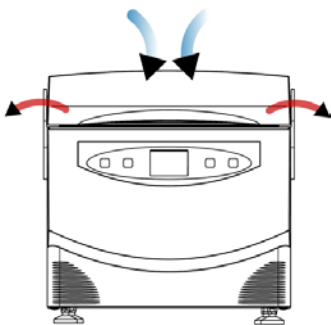

Le séchage prévoit que l'air soit prélevé de la partie arrière et que l'air chaud soit déchargé des côtés du dispositif.

Laisser au moins 50 mm d'espace libre des côtés.

6.1 Connexions

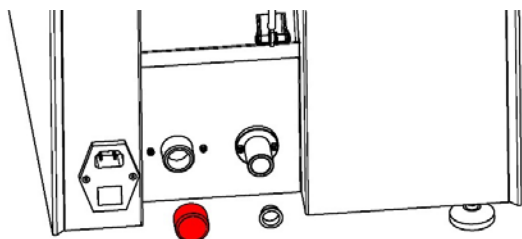

Enlever les bouchons de protection.

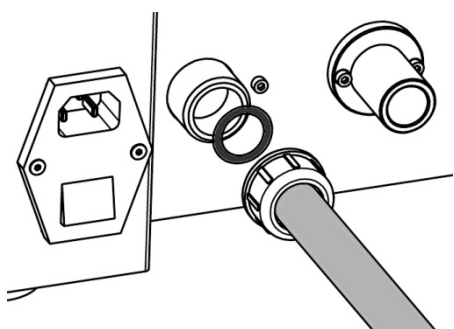

Tuyau de charge eau.

Connecter le tuyau au dispositif (O) en insérant son joint en caoutchouc. Connecter l'autre extrémité à la vanne d'alimentation.

OPTION : Un système anti-fuite (WATER BLOCK) est fourni en dotation. Ce dispositif doit être installé en aval de la vanne d'alimentation en position verticale. Voir les instructions du dispositif pour plus d'informations sur son installation et utilisation.

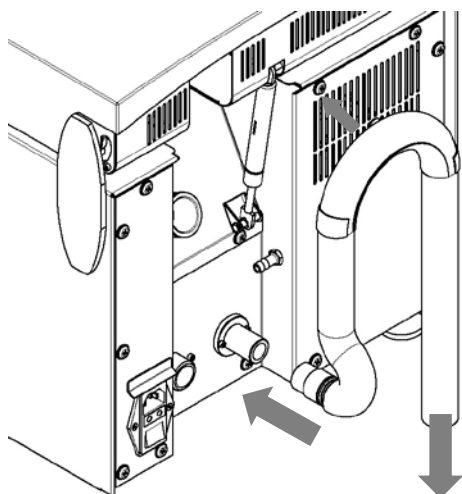

Tuyau de décharge de l'eau.

Enlever le bouchon de protection. Connecter le tuyau au dispositif (P). Relier l'autre extrémité au tuyau de décharge. Fixer en sécurité.



Installez le siphon comme indiqué sur la figure.

Tuyau de purge réservoir détergent

Porter le tuyau de purge transparent en dotation dans un point visible à la hauteur du plan d'appui de la machine ou en dessous. Ne pas obstruer ou tenir le tuyau immergé dans le liquide. Le tuyau de purge a aussi la fonction de trop-plein, lorsque le réservoir du détergent est plein, si on ajoute encore du détergent, ceci est déchargé par le tuyau de purge.

Câble d'alimentation



Contrôler l'intégrité du câble d'alimentation.

Connecter le câble d'alimentation à la prise sur l'arrière du dispositif (M).



Eviter de relier le dispositif à des rallonges ou à des adaptateurs

Allumer le dispositif par le biais de l'interrupteur (L).

Ouvrir la vanne d'alimentation eau et contrôler que le tuyau de charge ne présente pas de fuites (s'il perd, serrer davantage les raccords et contrôler que les joints d'étanchéité soit présents). Contrôler la présence du filtre dans la cuve et s'assurer qu'il soit propre.

6.2 Remplissage réservoir détergent:

Le réservoir a une capacité d'environ 2 l dont 0.5 l de réserve.
Pendant le remplissage le dispositif doit être allumé et afficher le message 'SELECTION CYCLE'.



ALLUMER TOUJOURS LA MACHINE AVANT DE CHARGER LE RESERVOIR DU DETERGENT

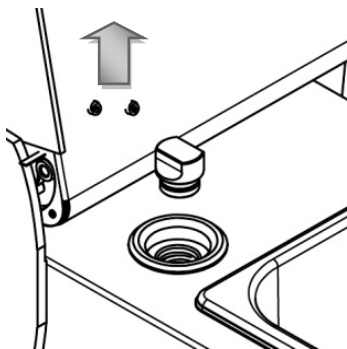

Ouvrir le couvercle de la cuve et soulever le bouchon (V) qui se trouve sur le côté gauche de la cuve.

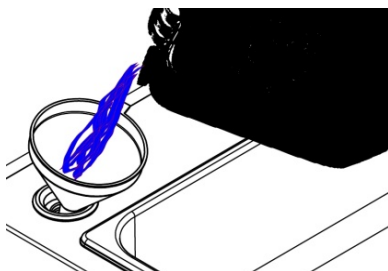

Injecter le liquide détergent (de préférence en utilisant l'entonnoir en dotation) jusqu'à quand un signal acoustique/visuel (sur l'écran) va communiquer que le réservoir est plein



N'utiliser que les liquides recommandés par le constructeur.



Ne pas mélanger les liquides à l'intérieur du réservoir puisque les réactions chimiques peuvent provoquer des dommages remarquables au dispositif.

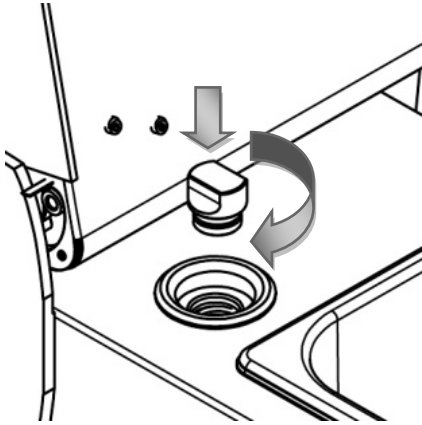

Abaisser et tourner légèrement pour fermer le bouchon entrée détergent.



Il est important de serrer le bouchon d'entrée détergent pour éviter que le détergent cristallise; la cristallisation du détergent pourrait causer l'obstruction et l'endommagement de quelques composants.



7 FONCTIONNEMENT DE L'APPAREIL





Le dispositif multifonction présente un couvercle relevable pour l'accès à la cuve de lavage.

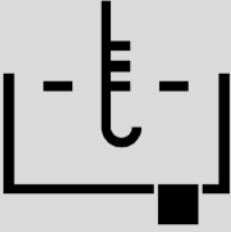

A l'intérieur de la cuve de lavage il faut positionner le panier, doté de supports en caoutchouc, contenant les instruments à nettoyer.

Le dispositif multifonction a un réservoir interne voué à contenir un détergent qui est dosé et injecté automatiquement dans la cuve de lavage pendant le cycle.

Un cycle de lavage complet prévoit les phases inscrites dans le tableau ci-dessous.

PHASE	SYMBOLE	DESCRIPTION	DUREE																																			
1		<p>Charge eau</p> <p>L'eau entre dans la cuve, en dépassant le bord du panier de 2 mm environ. Le volume total est de 6 l environ</p>	<p>1.5 min (P entrée = 2.5 bar)</p>																																			
2		<p>Entrée détergent</p> <p>Une pompe dose automatiquement et transfère du réservoir interne à la cuve la quantité fixée de détergent:</p> <table border="1" data-bbox="534 1299 1133 1836"> <thead> <tr> <th>Pourcentage sélectionné</th> <th>Volume (ml)</th> <th>cycles exécutables*</th> </tr> </thead> <tbody> <tr> <td>1%</td> <td>60</td> <td>≈25</td> </tr> <tr> <td>2%</td> <td>120</td> <td>≈12</td> </tr> <tr> <td>3%</td> <td>180</td> <td>≈8</td> </tr> <tr> <td>4%</td> <td>240</td> <td>≈6</td> </tr> <tr> <td>5%</td> <td>300</td> <td>≈5</td> </tr> <tr> <td>6%</td> <td>360</td> <td>≈4</td> </tr> </tbody> </table> <p><i>*le réservoir plein (1500 ml)</i></p>	Pourcentage sélectionné	Volume (ml)	cycles exécutables*	1%	60	≈25	2%	120	≈12	3%	180	≈8	4%	240	≈6	5%	300	≈5	6%	360	≈4	<table border="1" data-bbox="1236 1310 1380 1825"> <thead> <tr> <th>%</th> <th>sec</th> </tr> </thead> <tbody> <tr> <td>1</td> <td>80</td> </tr> <tr> <td>2</td> <td>160</td> </tr> <tr> <td>3</td> <td>240</td> </tr> <tr> <td>4</td> <td>320</td> </tr> <tr> <td>5</td> <td>400</td> </tr> <tr> <td>6</td> <td>480</td> </tr> </tbody> </table>	%	sec	1	80	2	160	3	240	4	320	5	400	6	480
Pourcentage sélectionné	Volume (ml)	cycles exécutables*																																				
1%	60	≈25																																				
2%	120	≈12																																				
3%	180	≈8																																				
4%	240	≈6																																				
5%	300	≈5																																				
6%	360	≈4																																				
%	sec																																					
1	80																																					
2	160																																					
3	240																																					
4	320																																					
5	400																																					
6	480																																					

3		<p>Réchauffement</p> <p>Le dispositif pendant les 5 premières minutes exécute le réchauffement ainsi qu'une première décontamination des instruments.</p> <p>Si le dispositif n'atteint pas la température fixée, le réchauffement continue même pendant le lavage.</p>	5 min ¹
4	 <p>CLIGNOTANT</p>	<p>Dégazage (DEGAS)</p> <p>Le dispositif continue ensuite en activant à intermittence les ultrasons pendant 5 minutes. Ce procédé réduit les gaz dissous dans le liquide en améliorant l'efficacité du lavage successif.</p>	5 min ¹
4S	<p>POUSSER START POUR PROCEDER</p>	<p>STANDBY</p> <p>Cette phase innovante permet de gérer des processus importants:</p> <ul style="list-style-type: none"> - Maintenir les instruments dans le liquide de nettoyage (TREMPAGE) - Ajouter des instruments (ATTENTION : MAX 1 KG. d'acier) <p>POUR SORTIR DE LA PHASE DE STANDBY ET TERMINER LE CYCLE AUTOMATIQUEMENT IL FAUT PRESSER START.</p>	
5		<p>SWEEP</p> <p>La fréquence des ultrasons est modulée en réduisant les effets négatifs des ondes stationnaires et en augmentant la distribution de l'énergie ultrasonore dans le liquide de nettoyage.</p> <p>Le nettoyage est plus efficace (la cavitation est améliorée)</p>	de 1 min à 30 min
6		<p>Décharge</p> <p>La cuve est vidée automatiquement</p>	≈ 1.5 min

7		Deuxième charge eau La cuve est remplie de nouveau pour rincer les instruments	1.5 min (P entrée = 2.5 bar)
8		Rinçage à ultrasons Activation des ultrasons pour un bref délai, rinçage par cavitation.	1 min
9		Décharge La cuve est vidée automatiquement	≈ 1.5 min
10		Séchage Pour sécher les instruments, la machine engendre un flux d'air chaud qui effleure les instruments et en élimine l'humidité sous la forme de vapeur.	15 min

Notes:

1 Les phases de réchauffement et dégazage, si les deux sont fixées, sont exécutées simultanément pour une durée totale de 5 minutes.

7.1 | Tableau des commandes

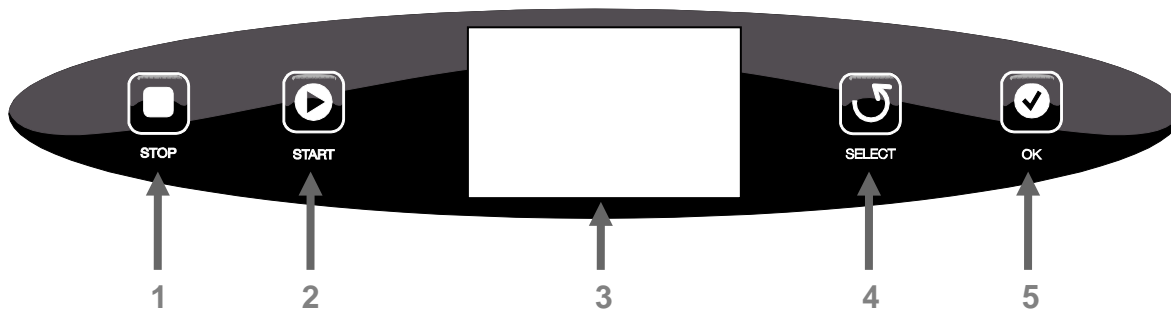

TOUCHES DEMARRAGE /INTERRUPTION CYCLE

1	STOP – ANNULE LE CYCLE En EXECUTION
2	START – DEMARRE LE CYCLE

TOUCHES DE PROGRAMMATION

4	SELECT – BOUTON POUR SURFER
5	OK – CONFIRMER LA SELECTION ET PASSER A LA SECTION SUCCESSIVE
3	DISPLAY

7.2 Sélection langue

Appuyer sur **STOP** pour 8 secondes.

Le visuel affiche la langue fixée.

Appuyer sur **SELECT** pour faire défiler les langues disponibles.

Appuyer sur **OK** pour confirmer la langue sélectionnée.

7.3 Sélection cycle

Lors de l'allumage le visuel affiche le logo du constructeur et la version du firmware (microprogramme).

Après 3 secondes de visuel affiche ce qui suit:

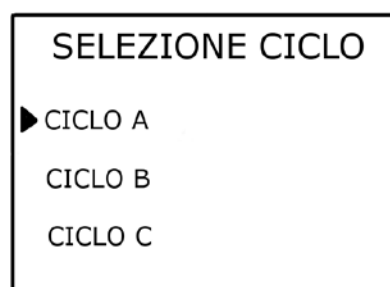

Appuyer sur **SELECT** pour faire défiler les programmes.

Appuyer sur **START** pour démarrer le cycle sélectionné.

7.4 Configuration standard des cycles

Le dispositif est fourni avec les paramètres déjà configurés à l'usine comme ci-dessous:

	A	B	C
Standby	ON	OFF	OFF
Entrée détergent	1 %	1 %	1 %
Réchauffement	ON	OFF	ON
Fonction Degas	OUI	OUI	OUI
Fonction SWEEP	NON	OUI	NON
Nettoyage à ultrasons	20 min	20 min	5 min
Séchage	OUI	OUI	OUI

Les paramètres fixés peuvent bien sûr être modifiés pour tous les cycles.

7.5 Modification des cycles

Sélectionner le cycle que l'on désire modifier. Appuyer sur la touche **OK** pour afficher le MENU.

Options disponibles:

Description	Paramètres fixés	Step
Standby	ON - OFF	-
Entrée détergent	0 ÷ 6 %	1%
Réchauffement	ON - OFF	-
Fonction Degas	OUI - NON	-
Fonction SWEEP	OUI - NON	-
Nettoyage à ultrasons	0 ÷ 30 min	1 min
Séchage	OUI - NON	-

Appuyer sur la touche **OK** pour faire défiler les paramètres du cycle.

Appuyer sur la touche **SELECT** pour modifier la valeur du paramètre sélectionné.

Le menu des paramètres et des options sont à défilement circulaire.

Une fois la configuration achevée, sélectionner EXIT et appuyer sur **SELECT** pour sortir du MENU.

Les changements seront sauvegardés.

7.6 Configuration DEMARRAGE RETARDE:

Appuyer sur **START** et garder abaissé pour 8 secondes.

Appuyer sur **SELECT** pour faire défiler les valeurs de 1 à 9 heures.

Appuyer sur **START** pour démarrer le départ retardé.

Pendant l'attente un temporisateur sera affiché qui affichera le temps résiduel avant le démarrage du cycle.

ATTENTION: En cas de manque de tension le démarrage retardé sera annulé.

8 MODE D'EMPLOI

Ouvrir la vanne d'alimentation eau. Vérifier la présence du filtre dans la cuve et s'assurer qu'il soit bien propre. Positionner les instruments à nettoyer dans le PANIER dédié, s'il y a des instruments ou objets de petites dimensions, utiliser le PANIER PORTE-FRAISES en dotation.

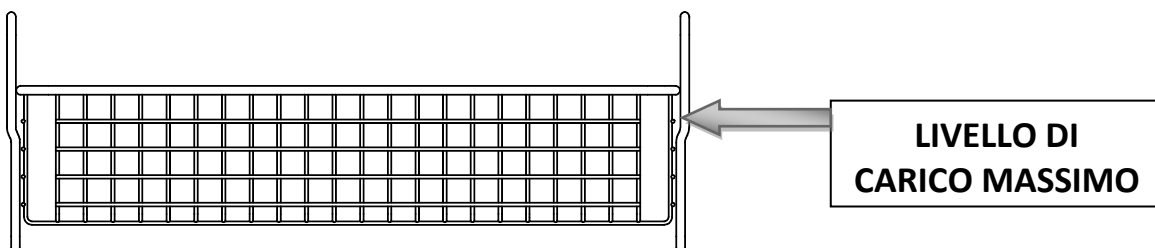

La charge doit se faire en distribuant de manière uniforme les instruments à nettoyer en prenant garde à ce que ils ne heurtent pas les parois ou le fond de la cuve.

Introduire le panier à l'intérieur de la cuve en prenant garde à ce qu'il ne touche pas ses parois. Il est important de prétraiter les ciments, les alginates et les composites avec des liquides spécifiques.

Si les instruments sont très sales, il faut enlever un peu de saleté avant d'introduire les instruments dans le panier pour éviter d'obstruer les filtres de décharge.

Pour éviter le contact entre les pieds en acier du panier et la cuve de nettoyage il faut insérer des supports en caoutchouc prévus à cet effet. Au cas où il seraient endommagés ou absents, insérer de nouveaux supports en caoutchouc. Une utilisation erronée peut causer des dommages à la cuve. Allumer le dispositif par l'interrupteur (L).

Démarrer le cycle sélectionné en appuyant sur **START** le dispositif affiche la phase du cycle en cours et le compte à rebours du temps (temps prévu) nécessaire pour achever le cycle.

Si la phase du cycle prévoit la phase de STANDBY il faut appuyer **START** une deuxième fois (après les phases de chargement de l'eau, d'entrée de détergent, Degas et le chauffage) pour aller à l'étape de lavage et terminer le cycle sélectionné.

Au terme du cycle le message ' **END CYCLE OK** ' est affiché et accompagné par un signal acoustique. Appuyer sur OK pour revenir sur la sélection du cycle.

Si le couvercle est ouvert lorsque le dispositif est en marche, le phase de travail en cours est bloquée immédiatement. Si on ferme le couvercle le cycle de travail va reprendre exactement la où il a été interrompu.



A la fin de la journée fermer la vanne installée en amont du dispositif.



ne pas toucher les instruments, le couvercle et la résistance pendant le séchage. Danger de brûlures.



Vidanger complètement le réservoir avant d'y introduire un détergent différent de celui qu'on a utilisé préalablement

Utiliser un détergent différent de celui qui est contenu dans le réservoir:

Il est possible d'utiliser un détergent différent de celui qui est contenu dans le réservoir.

Sélectionner l'option 'NON' dans le menu du cycle qu'on désire exécuter en ce qui concerne l'entrée automatique du détergent.

Démarrer le cycle, après quelques minutes (à la fin de la phase de charge de l'eau) le dispositif lance un signal acoustique; à ce moment il est possible d'ouvrir le couvercle et d'injecter directement dans la cuve le pourcentage (1% - 60ml) désiré de détergent. Fermer le couvercle pour achever le cycle.

Vidange réservoir du détergent:

Pendant l'utilisation du dispositif, à la demande d'ajouter le détergent, si on désire vidanger complètement le réservoir du détergent, maintenir la touche **SELECT** abaissée et en même temps appuyer sur la touche **OK** et la maintenir abaissée.

Après 5 secondes la pompe péristaltique démarre, dans cette phase le dispositif produit un signal acoustique intermittent qui ne s'interrompt que lorsque la phase se termine, le détergent sera déchargé directement dans la cuve à travers la buse qui se trouve sur le couvercle(I).

Après 10 minutes environ ouvrir légèrement le couvercle (sans faire déclencher le capteur d'ouverture couvercle) et contrôler qu'il n'y ait pas de fuites de détergent de la buse.

Une fois la vidange terminée, interrompre la phase par le biais de la touche **STOP**.

9

ENTRETIEN

9.1 NETTOYAGE

Le nettoyage doit se faire lorsque le dispositif s'est refroidi et le câble d'alimentation est débranché.



Utiliser des détergents non agressifs pour le plastique



Utiliser des détergents idoines pour l'acier inox

9.2 Nettoyage de la cuve



Vérifier le nettoyage de la cuve à la fin de chaque cycle

Éliminer tout éventuel dépôt ou déchet pour éviter d'introduire dans le circuit de décharge des matériaux qui peuvent causer des obstructions.

9.3 Nettoyage du filtre de la cuve



Vérifier le nettoyage du filtre cuve à la fin de chaque cycle.

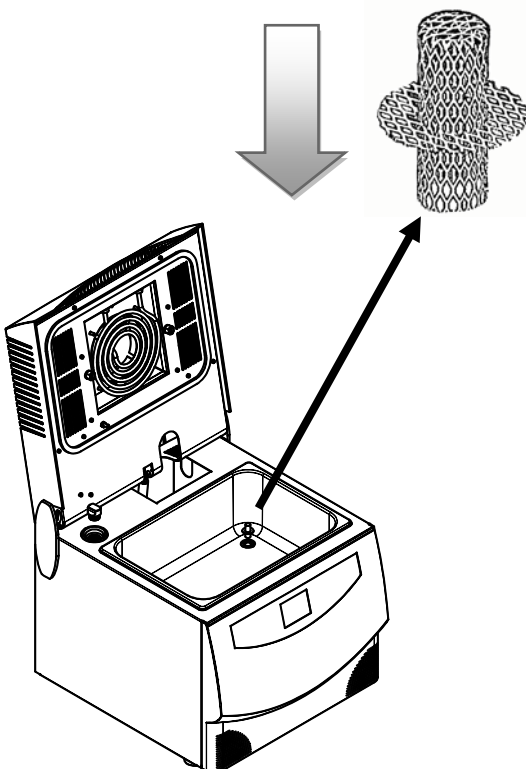

Soulever le couvercle du dispositif;

Éliminer les résidus présents dans la cuve.

Extraire le filtre métallique présent dans la cuve en le tirant vers le haut comme on l'indique dans la figure;

Laver le filtre à l'eau courante pour éliminer toutes les impuretés présentes.

Repositionner le filtre dans son logement en prenant garde que la partie ouverte du filtre soit bien insérée dans le raccord de décharge et que la partie fermée soit positionnée en vue dans la cuve.

9.4 Nettoyage du filtre d'entrée de l'eau

A contrôler périodiquement.

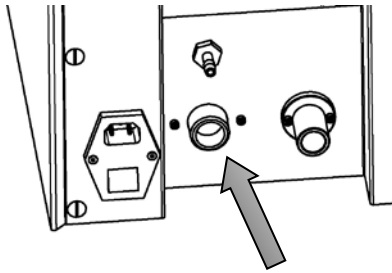

Fermer l'alimentation d'eau, enlever le tuyau de charge de l'eau, s'assurer que le filtre (O) soit bien propre.

Dans le cas contraire, à l'aide d'une pince extraire le filtre sans le forcer et le laver à l'eau.

Remonter le filtre ainsi que le tuyau d'alimentation.

9.5 NETTOYAGE DE LA SONDE DE NIVEAU

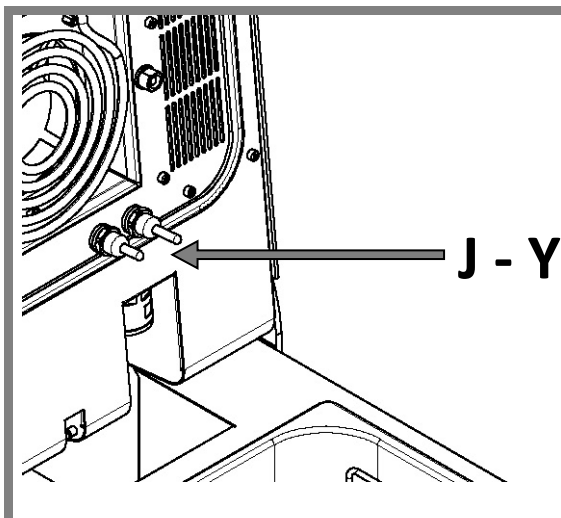

Contrôler régulièrement le **PROBE J - Y**
(tous les 2-3 cycles)

Nettoyez le métal avec des produits appropriés pour l'acier inoxydable ou bien un produit décapant.

Utiliser un éponge un peu émeri.

9.6 Entretien programmé



Utiliser uniquement des pièces de rechange d'origine

Description	Périodicité	Exécuteur
Remplacement tuyau pompe péristaltique.	Annuelle	Techniciens autorisés
Contrôle rotor de ventilation séchage	Annuelle	Techniciens autorisés
Filtre cuve	Si nécessaire	Utilisateur
Joint bouchon détergent	Si nécessaire	Utilisateur
Joint couvercle	Si nécessaire	Techniciens autorisés



Les opérations d'**entretien et réparation** doivent être accomplies le dispositif débranché de l'alimentation électrique.

Un bon entretien du dispositif assure un bon fonctionnement du dispositif et permet d'économiser le temps et les coûts d'assistance.

10

SIGNALISATIONS - ERREURS

10.1 Signalisations

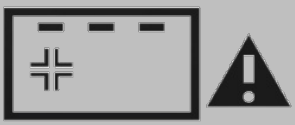

Display	Cause	Solution
	Le couvercle est ouvert.	Fermer le couvercle.
	Le liquide détergent dans le réservoir est insuffisant (≤ 0.5 l)	Remplir le réservoir du détergent et redémarrer le cycle ou programmer un cycle sans détergent.
	Le réservoir du détergent est plein.	Interrompre le remplissage du réservoir détergent. Si on continue le remplissage, le détergent sortira du tuyau arrière du trop-plein.

10.2 Erreurs

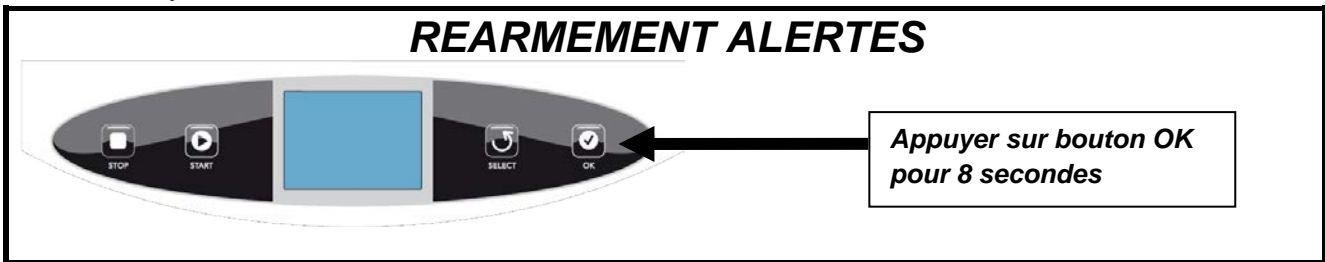
En cas de signalisation d'erreur il faut réarmer le dispositif pour pouvoir démarrer un nouveau cycle.

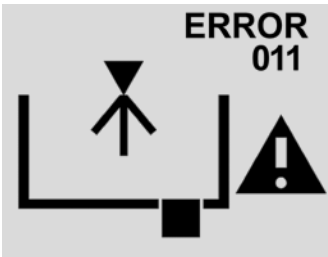

Display	Causes	Solutions
<p>ERROR 005</p>	<p>Anomalie entrée eau</p> <ul style="list-style-type: none"> - vanne fermée - Filtres obstrués - Anomalie de pression dans l'installation d'alimentation de l'eau 	<ul style="list-style-type: none"> - Contrôler que la vanne soit ouverte. - Nettoyer le filtre entrée eau. - Contrôler que la pression de l'eau soit dans les limites indiquées. Si insuffisante, consulter un plombier pour évaluer les possibles remèdes. - Contrôler que le Water Block (OPTION) ne soit pas bloqué. - Contrôler qu'il n'y ait pas d'eau dans la cuve et démarrer un nouveau cycle
<p>ERROR 010</p>	<p>Anomalie niveau eau</p> <ul style="list-style-type: none"> - Le dispositif a été déplacé ou incliné pendant le lavage. - On a ajouté beaucoup d'instruments après la charge d'eau. 	<ul style="list-style-type: none"> - S'assurer qu'il n'y ait pas d'eau dans la cuve et redémarrer le cycle. - Ne pas ajouter des instruments pendant le cycle.
<p>ERROR 008</p>	<p>Anomalie décharge eau</p> <ul style="list-style-type: none"> - Filtres obstrués. - Rupture pompe de vidange 	<ul style="list-style-type: none"> - Nettoyer le filtre dans la cuve. - S'assurer qu'il n'y ait pas d'eau dans la cuve et redémarrer le cycle.

Display	Causes	Solutions
	<p>Anomalie entrée eau</p>	<p>PROBE J - Y</p> <p>Nettoyez le métal avec des produits appropriés pour l'acier inoxydable ou bien un produit décapant. Utiliser un éponge un peu émeri.</p>
	<p>Anomalie entrée eau Anomalie de pression dans l'installation d'alimentation de l'eau</p>	<p>PROBE J - Y</p> <p>Nettoyez le métal avec des produits appropriés pour l'acier inoxydable ou bien un produit décapant. Utiliser un éponge un peu émeri. Contrôler que la pression de l'eau soit dans les limites indiquées. Si insuffisante, consulter un plombier pour évaluer les possibles remèdes.</p>

VIDANGE EAU DANS LA CUVE
ON DEMARRE POMPE DE VIDANGE POUR 30 SECONDES



Appuyer sur bouton OK pour 8 secondes

10.4 Problèmes génériques

Problèmes	Causes possibles	Solutions
Nettoyage insuffisant	- Eau calcaire, halos blancs présents sur les instruments	- Installer un adoucisseur en amont. - Quelques détergents peuvent réduire ce phénomène
	- Présence d'éléments non prétraités (ciments, alginates)	- Prétraiter avec des détergents adaptés.
	- Configurations du cycle non correctes	- Changer les paramètres, en augmentant le temps de nettoyage.
	- On ne perçoit pas le bruit des ultrasons pendant la phase de nettoyage	- S'adresser au service d'assistance technique
Séchage insuffisant	- Charge excessive, présence de gouttes parmi les instruments	- Réduire la charge
	- Installation incorrecte, présence d'un film d'eau sur le fond de la cuve après la décharge.	- Positionner le dispositif correctement, modifier la hauteur des pieds
	- On ne perçoit pas le flux d'air à travers les fentes latérales du couvercle	- S'adresser au service d'assistance technique
Quelques instruments s'endommagent	- Instruments non idoines au nettoyage par ultrasons (ex. miroirs dentaires)	- Ne pas nettoyer par ultrasons des instruments non idoines

11 | PROCEDURES POUR LE SERVICE ET L'ASSISTANCE

En cas de défaillance ou de révision contacter directement l'assistance après vente téléphonique.

PHONE	+39 0521 8380
FAX	+39 0521 833391
@	service@tecnogaz.com

Ce sera le service d'assistance après vente à évaluer l'opportunité du retour à l'usine ou bien de l'intervention d'un technicien et, après avoir inspecté l'appareillage, ce sera le service à rédiger un devis des frais et dépenses qui sera envoyé au client distributeur qui, à son tour, va le remettre au client final, pour signature et approbation.

Après avoir reçu le devis signé et approuvé, l'intervention de réparation sur la cuve sera démarrée et la cuve sera envoyée dans les temps indiqués sur le devis.

Au cas où il serait nécessaire d'envoyer la cuve à l'usine, s'en tenir aux indications obligatoires dont ci-dessous:

- Utiliser l'emballage d'origine; si non disponible, utiliser un emballage adéquat. La marchandise voyage aux risques et périls de l'expéditeur.
- Envoyer uniquement la cuve multifonction (ne insérer aucun composant contenu dans le kit accessoires).
- Nettoyer soigneusement la cuve en entier avant de l'envoyer. Au cas où elle serait rendue à l'usine sale et avec des résidus, la cuve sera renvoyée au client non réparée ou bien elle sera soumise à nettoyage et désinfection.
- Décharger toujours le réservoir du détergent.
- Indiquer par écrit et insérer dans l'emballage un document indiquant avec précision l'anomalie détectée ou bien le service d'assistance que l'on demande.
- Envoyer toujours franco de port dans le cas contraire les frais de port soutenus seront à la charge du client.

Tous les emballages non d'origine qui nous parviendront seront écoulés.

La machine sera renvoyée dans l'emballage d'origine (le coût de l'emballage sera à la charge du client) en utilisant le transporteur du client.

A

ACCESSOIRES

	DESCRIPTION	CODE
	PANIER (180 mm X 280 mm H60 mm)	DVMA069
	JOINTS PIEDS	DFAA493
	PORTE-FRAISES (D 70 mm H 60 mm)	DVMA072
	TUYAU DE CHARGE (L 3 mt)	CPLA002
	TUYAU DE DECHARGE (L 0.8-2.7 mt)	CPLA001
	CABLE D'ALIMENTATION (L 2.5 mt)	CECG006
	ENTONNOIR	CPMG001
	WATER BLOCK (OPTION)	DVMA092
	FILTRE CUVE	DVMA115
	PORTE-PLATEAUX (OPTION)	VM801ZVM
	N°1 PLATEAUX (OPTION)	SVMA070
	LIQUIDE DETERGENT/DESINFECTANT DILUTION POUR LAVAGE A ULTRASON: 1 % CONDITIONNEMENT : 6 BOUTEILLES DE 1,0 L	DM401ALP

B

DESSINS

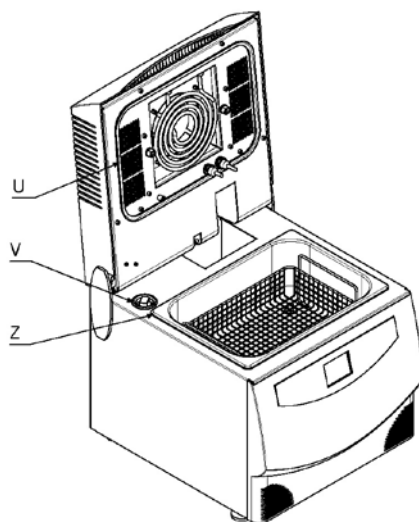
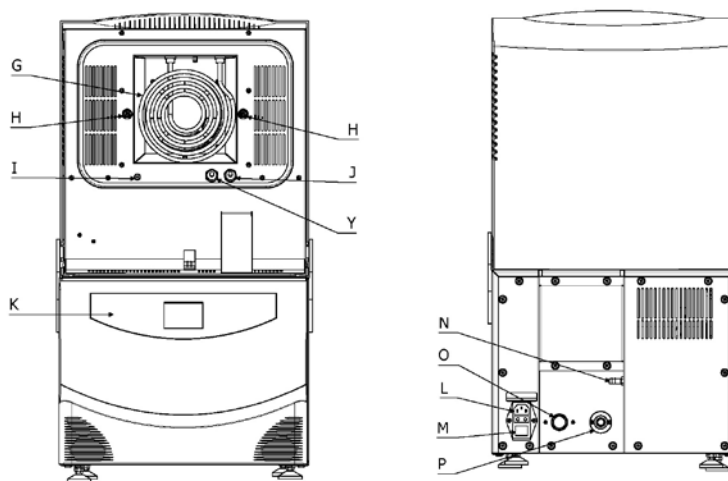
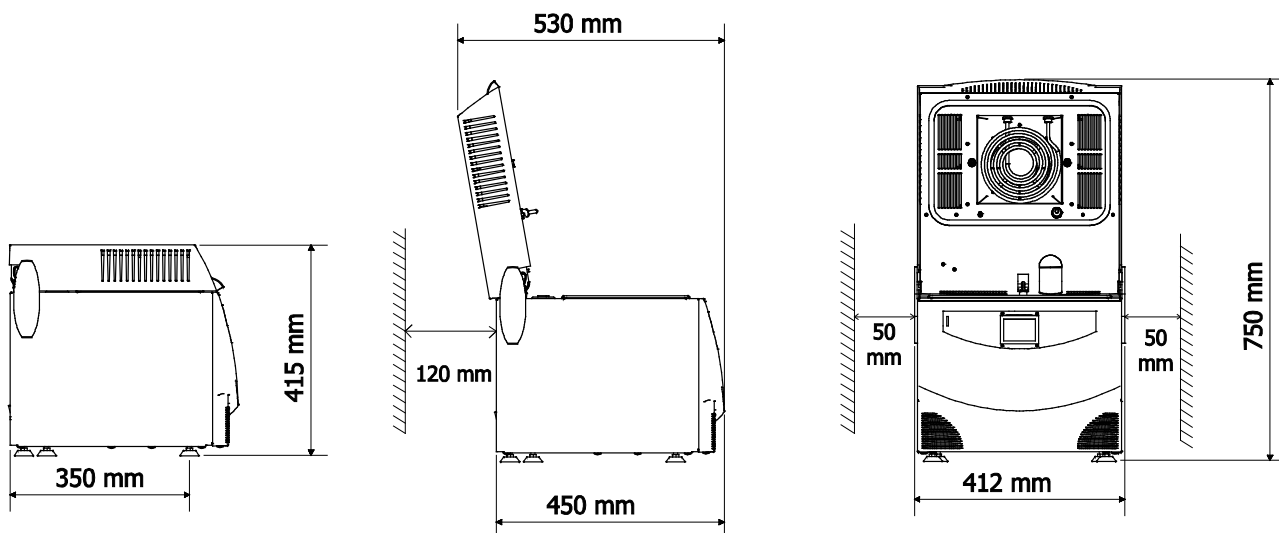

INHALTSVERZEICHNIS

1. EINSATZ UND VERWENDUNGSZIEL DES GERÄTS

2. SICHERHEIT

- 2.1 SICHERHEITSMARKIERUNG
- 2.2 SICHERHEITSVORRICHTUNGEN
- 2.3 ENTSORGUNG

3. TECHNISCHE DATEN

4. AUSPACKEN

5. BESTANDTEILE

6. INSTALLATION

- 6.1 ANSCHLÜSSE
- 6.2 FÜLLUNG VOM REINIGUNGSMITTELTANK

7. BETRIEB DES GERÄTS

- 7.1 BEDIENPANEEL
- 7.2 SPRACHENWAHL
- 7.3 ZYKLUSWAHL
- 7.4 STANDARDEINSTELLUNGEN DER ZYKLEN
- 7.5 ÄNDERUNG DER ZYKLEN
- 7.6 EINSTELLUNG STARTVERZÖGERUNG

8. GEBRAUCHSANLEITUNG

9. WARTUNG

- 9.1 REINIGUNG
- 9.2 REINIGUNG DER WANNE
- 9.3 REINIGUNG DES WANNENFILTERS
- 9.4 REINIGUNG DES WASSEREINTRITTSFILTERS
- 9.5 NIVEAUSONDEREINIGUNG
- 9.6 PROGRAMMIERTE WARTUNG

10. SIGNALE – FEHLER

- 10.1 SIGNALE
- 10.2 FEHLER
- 10.4 ALLGEMEINE PROBLEME

11. KUNDENDIENSTVERFAHREN

- A. ZUBEHÖRTEILE**
- B. ZEICHNUNGEN**

1 EINSATZ UND VERWENDUNGSZIEL

VERWENDUNGSZIEL	Die Multifunktionswanne wurde so entwickelt, um die organische und unorganische Reste zu entfernen, und die Instrumenten zu trocknen. Das kann im Medizin-, Dental-, ästhetische und Tierärztlichenbereich benutzt werden.
------------------------	--

Das Gerät ermöglicht mithilfe der Ultraschallreinigung die Reinigung von bei einer manuellen Reinigung schwer zugänglichen Stellen ohne die von der Handhabung von verunreinigten Instrumenten verursachten Gefahren.

Das Gerät kann 3 vom Benutzer einstellbare Zyklen speichern.

Die wichtigsten Phasen sind:

REINIGUNG	Phase, die den Umfang der mikrobiellen Verunreinigung um über 90% reduziert. Diese Phase beseitigt das organische und unorganische.
SPÜLGANG	Diese Phase beseitigt eventuelle in der Wanne vorhandene Reinigungsmittelrückstände.
TROCKNUNG	Nach dem Spülgang müssen die Vorrichtungen getrocknet werden, um Wasserrückstände zu vermeiden, die das anschließende Sterilisierverfahren beeinträchtigen können

	Die Multifunktionswanne darf <u>nur</u> für die Reinigung von mit der Ultraschallwaschanlage kompatiblen Instrumenten und Materialien und generell nur für die vom Hersteller vorgesehenen Verwendungen gebraucht werden.
---	---

2

SICHERHEIT

	Das Gerät darf nicht in potentiell explosiver Atmosphäre verwendet werden.
	Das Gerät fernab von Wärmequellen oder elektromagnetischen Strahlungen positionieren.
	Das Gerät so positionieren, dass das Steuerbrett und der Bildschirm vom Benutzer klar sichtbar sind.
	Die Elektroanlage muss mit der geltenden Bestimmung übereinstimmen, prüfen, dass die Anlage für die Geräteigenschaften angemessen ist.
	Die Unversehrtheit des Netzkabels kontrollieren.
	Keine entzündlichen Reinigungsmittel verwenden
	Keine Säuren (z.B. HCl) oder Chloride in die Wanne einfüllen
	Keine den Wannenboden berührende Gegenstände hineinlegen
	Der Hersteller haftet im Sinne der geltenden Bestimmung für das auf den Markt gebrachte Produkt. Die <u>Haftung erlischt</u> in dem Moment, in dem von <u>nicht qualifiziertem Personal oder unter Verwendung von Nichtoriginal-Ersatzteilen</u> Eingriffe am Gerät oder an Teilen davon durchgeführt werden.
	DAS GERÄT NICHT ÖFFNEN. Bei Störungen oder Gefahr des Eindringens von Flüssigkeiten in das Gerät, bei Wartung und Reinigung des Geräts das Stromnetzkabel abtrennen.
	Das Schild nicht entfernen
	Vor irgendeinem Eingriff das Netzkabel aus der Netzsteckdose ziehen.
	Bitte beachten Sie Sicherheitsanleitungen vom Reinigungsmittel.
	Die Ultraschalle können unter bestimmten Bedingungen für das Gehör unangenehme Geräusche erzeugen. Geeignete PSA tragen.

2.1 Sicherheitsmarkierung

	<p>GEFÄHRLICHE SPANNUNG</p>
 <p>ATTENZIONE ATTENTION ATTENTION ACHTUNG</p> <p>ALTA TEMPERATURA HIGH TEMPERATURES TEMPERATURES ELEVÉES HOHE TEMPERATUR</p>	<p>HOHE TEMPERATUR</p>
	<p>ERDUNG</p>

2.2 Sicherheitsvorrichtungen

-) Sensor für Klappenöffnung
-) Sicherheitsthermostate
-) Wasserzufuhrkontrollsystem

2.3 Entsorgung



Dieses Produkt unterliegt der Richtlinie 2002/96/EG des europäischen Parlaments und des Rats der europäischen Gemeinschaft über die Abfälle von elektrischen Geräten (WEEE). In den Rechtsprechungen, die diese Richtlinie anwenden, wurde das Produkt nach dem 13. August 2005 auf den Markt gebracht und es darf nicht als nicht recycelbarer Hausmüll entsorgt werden. Die entsprechenden örtlichen WEEE Sammelstellen für die Entsorgung dieses Produkts in Anspruch nehmen bzw. sich an die geltenden Bestimmungen halten.

3

TECHNISCHE DATEN

MECHANISCHE		
Betriebstemperatur	+5°C ÷ +30°C	
MAX relative Luftfeuchtigkeit bei 30°C	80%	
Abmessungen (LxHxT)	415 x 415 x 530 mm	
Höhe mit offenem Deckel	750 mm	
Tiefe mit offenem Deckel	530 mm	
Gewicht (leerer Behälter)	20 kg	
ELEKTRISCHE		
Speisungsspannung	230 V a.c. +/-10 % single phase	
MAX aufgenommene Leistung	1 kW	
Frequenz	50 / 60 Hz	
Netzkabel	2 + 1 x 1mm ²	
Sicherungen	6.3 A (5 x 20)	
ULTRASCHALL		
Anz. Transduktoren	4	
Frequenz	39 KHz	
WASSERSPEISUNG		
Wasserdruck	1.5 ÷ 2 Bar	
Leitfähigkeit von Wasser	> 50 µS/cm	
MAX Temperatur	+30°C	
Maße Zuflussschlauch	3/8 G / Länge 3 m	
WANNE		
Fassungsvermögen Wanne	9 l (Edelstahl AISI 316)	
Wasserfüllmenge	6 l	
TANKBEHÄLTER REINIGUNGSMITTEL		
Fassungsvermögen	1.5 l + 0.5 l (Reserve)	
Mit vollem Tankbehälter durchführbare Zyklen	Ausgewählter Prozentsatz	Durchführbare Zyklen*
	1%	≈25
	2%	≈12
	3%	≈8
	4%	≈6
	5%	≈5
6%	≈4	
Material	Polyethylen	
FILTER		
Wannenfilter	Edelstahl AISI 304	

Die Verpackung darf nicht gestoßen werden, muss sorgfältig gehandhabt und darf nicht gerollt oder fallen gelassen werden.

Das Gerät wird mit einer Holzpalette gestützt und ist in einem innen mit Pappgemischen verstärkten Wellpappkarton eingeschlossen.

Den Wellpappkarton öffnen, die Verstärkungsteile entfernen und das Gerät nur mithilfe der mitgelieferten Riemen herausnehmen.



Der Transport des Geräts darf nur unter Verwendung der Riemen erfolgen. Das Gerät nie durch Anfassen am Bedienfeld anheben. Diese falsche Tätigkeit könnte das Gerät beschädigen.



Die Verpackung muss über die gesamte Garantiezeit aufbewahrt werden. Der Hersteller akzeptiert keine Rückgaben ohne Original-Verpackung.



Keine Geräte mit offensichtlichen, durch den Transport bedingten Schäden verwenden.



Die Verpackung entfernen und den Gerätezustand kontrollieren.

INHALT:

- **MULTIFUNKTIONSWANNE**
- **GEBRAUCHSANLEITUNG:** Ist aufmerksam zu lesen und an einem allen mit dem Betrieb des Geräts beauftragten Benutzer zugänglichen Ort aufzubewahren.
- **KONFORMITÄTSERKLÄRUNG :** Ist aufzubewahren.
- **INSTALLATIONS- ABNAHMEPROTOKOLL UND GARANTIEBEDINGUNGEN:** Sind bei der Installation der Maschine unter Befolgung der im Formular wiedergegebenen Angaben auszufüllen.
- **SCHNELL-GEBRAUCHSANLEITUNG:** Ist in Maschinennähe aufzubewahren.
- Wasserversorgungsschlauch
- Abflussschlauch
- Entlüftungsröhr Reinigungsmittel
- Netzkabel
- Standard-Körbchen
- Fräsenkörbchen
- Packung empfohlenes Reinigungsmittel

05**BESCHREIBUNG DER BESTANDTEILE**

Auf Anlage B – ZEICHNUNGEN Bezug nehmen

G	Widerstand Trocknung
H	Wasserdüsen
I	Reinigungsmitteldüse
J - Y	Sonde
K	Tastenfeld und LCD
L	Hauptschalter
M	Netzstecker mit Sicherungskörpern
N	Entlüfter Reinigungsmittelbehälter mit Überlauffunktion
O	Wassereintritt (3/8 G)
P	Abflussanschluss
R	Gasfeder
U	Deckeldichtung
V	Kollektor Reinigungsmittel
Z	Edelstahlwanne



Das Gerät darf nicht in potentiell explosiver Atmosphäre verwendet werden.



Das Gerät fernab von Wärmequellen oder elektromagnetischen Strahlungen positionieren.



Das Gerät so positionieren, dass das Steuerbrett und der Bildschirm vom Benutzer klar sichtbar sind.



Die Elektroanlage muss mit der geltenden Bestimmung übereinstimmen, prüfen, dass die Anlage für die Geräteeigenschaften angemessen ist.

Den Deckel öffnen und die in der Wanne enthaltenen Zubehörteile herausnehmen.

Auf einer perfekt waagerechten und festen Oberfläche positionieren, die Lasten von mindestens **35 kg** aushalten kann. Die Stützfüße des Geräts lassen sich regulieren und ermöglichen Feineinstellungen;



Eine falsche Neigung verursacht das Stehen von Wasser auf dem Wannensboden mit Problemen bei der Trocknung

Das Gerät so positionieren, dass der Benutzer die Wanne leicht inspizieren und reinigen kann; der Benutzer muss für die Filterreinigung an die Geräterückseite gelangen können.

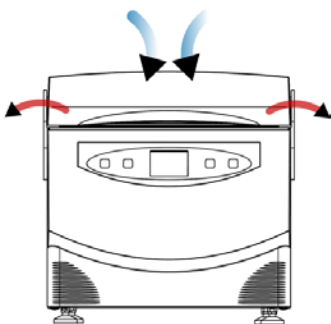

Die Trocknung sieht vor, dass Luft von der Rückseite aufgenommen und Warmluft von den Geräteseiten abgegeben wird.

An den Seiten einen Freiraum von mindestens 50 mm lassen.

6.1 | Anschlüsse

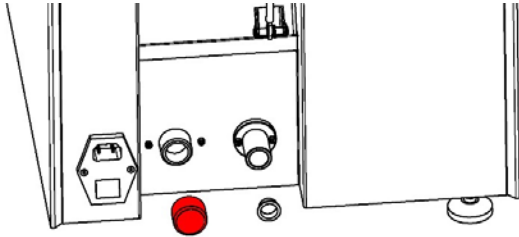

Die Schutzkappen entfernen.

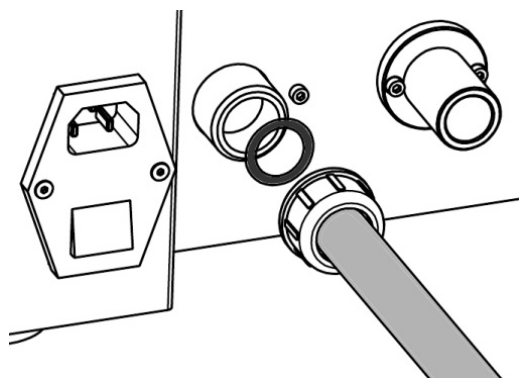

Wasserzufuhrschlauch.

Den Schlauch an das Gerät (**O**) durch Einlegen der entsprechenden Gummidichtung anschließen. Das andere Ende an den Zufuhrhahn anschließen.

ZUBEHÖR: Notblockiersystem für Wasserfluss (WATER BLOCK). Diese Vorrichtung muss unmittelbar unterhalb des Zufuhrhahns vertikal installiert werden. Für weitere Informationen über die Installation und Gebrauch der selbigen siehe Anleitung der Vorrichtung.

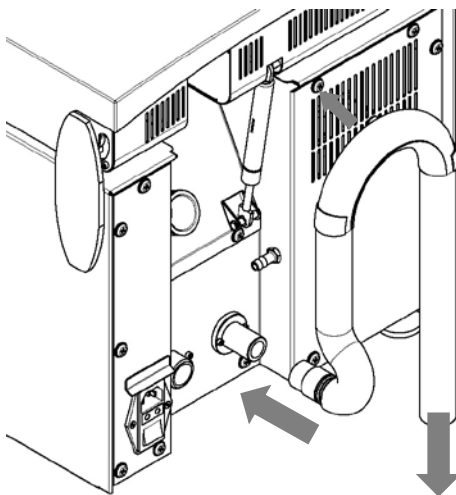

Wasserabflussschlauch.

Die Schutzkappe entfernen. Den Schlauch an die Vorrichtung (**P**) anschließen. Das andere Ende an den Abfluss anschließen.



Installieren Sie den Siphon wie in der Abbildung gezeigt

Entlüftungsrohr Reinigungsmittelbehälter

Das durchsichtige, mitgelieferte Entlüftungsrohr an eine auf der Höhe der Auflagefläche der Maschine oder darunter sichtbaren Stelle führen. Nicht verstopfen oder in die Flüssigkeit eingetaucht halten. Das Entlüftungsrohr hat auch die Überlauffunktion, wenn der Reinigungsmittelbehälter voll ist und weiteres Reinigungsmittel eingefüllt wird, wird dieses über das Entlüftungsrohr abgelassen.

Netzkabel



Die Unversehrtheit des Netzkabels kontrollieren.

Das Netzkabel an die auf der Geräterückseite angebrachte Steckdose (**M**) anschließen.



Anschlüsse mit Verlängerungskabeln, Reduzierungen oder Adaptern vermeiden

Die Maschine mit dem entsprechenden Schalter (**L**) einschalten.

Den Wasserzufuhrhahn aufdrehen und kontrollieren, dass der Zufuhrschlauch keine Lecks aufweist (wenn er tropft, die Anschlüsse weiter anziehen und das Vorhandensein der Dichtungen kontrollieren). Das Vorhandensein des Filters in der Wanne und die Sauberkeit des selbigen kontrollieren.

6.2 Füllung von Reinigungsmitteltank

Der Behälter fasst circa 2 l, davon sind 0,5 l Reserve.
Während des Füllens muss das Gerät eingeschaltet sein und 'ZYKLUSWAHL' anzeigen.



DIE MASCHINE STETS VOR DEM FÜLLEN DES REINIGUNGSMITTELBEHÄLTERS EINSCHALTEN

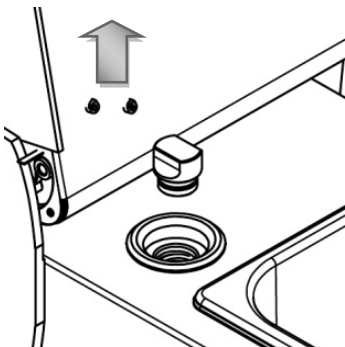

Den Deckel der Wanne öffnen und den auf der linken Wannenseite angebrachten Verschluss (**V**) anheben.

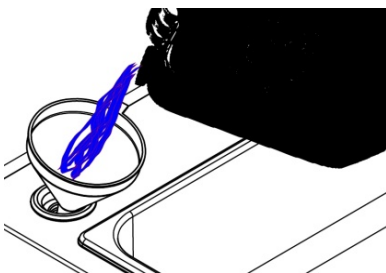

Füllen Sie das Reinigungsmittel durch den zusammengelieferten Trichter, bis wann ein Signalton oder Signalanzeige im Display auftritt, das der Tank voll ist



Nur vom Hersteller empfohlene Flüssigkeiten verwenden.



Keine Flüssigkeiten im Behälter mischen, da die daraus resultierenden chemischen Reaktionen beachtliche Schäden am Gerät verursachen können.

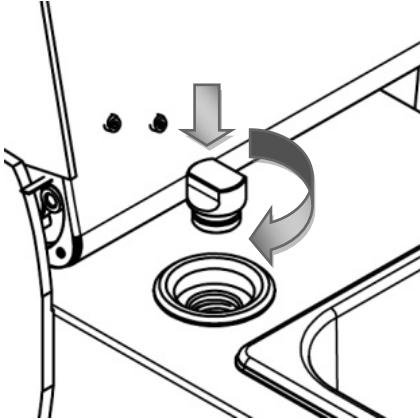

Den Verschluss der Reinigungsmiteleintrittsöffnung drücken und leicht zum Schließen drehen.



Es wichtig, den Verschluss der Reinigungsmiteleintrittsöffnung zu schließen, um zu vermeiden, dass das Reinigungsmittel kristallisiert, die Kristallisierung des Reinigungsmittels könnte die Verstopfung und die Beschädigung einiger Bestandteile verursachen.



7 BETRIEB DES GERÄTS

Das Multifunktionsgerät verfügt über einen aufklappbaren Deckel für den Zugang zur Reinigungswanne.

Das entsprechende, mit Gummistützfüßchen versehene und mit den zu reinigenden Gegenständen gefüllte Körbchen muss in die Reinigungswanne gestellt werden.

Das Multifunktionsgerät ist mit einem internen Tank für das Reinigungsmittel ausgestattet, das wird während des Zyklus automatisch dosiert, und in die Reinigungswanne eingespritzt.

Ein kompletter Reinigungszyklus sieht die in der folgenden Tabelle angegebenen Phasen vor.

PHASE	SYMBOL	BESCHREIBUNG	DAUER																																			
1		<p>Wasser einfüllen</p> <p>Das Wasser gelangt in die Wanne und überschreitet den Rand des Körbchens um circa 2 mm.</p> <p>Das Gesamtfassungsvermögen beträgt circa 6 l.</p>	<p>1.5 Min</p> <p>(P Eintritt = 2.5 bar)</p>																																			
2		<p>Reinigungsmitteldosierung</p> <p>Eine Pumpe dosiert automatisch die eingestellte Reinigungsmittelmenge und befördert sie vom Behälter in die Wanne:</p> <table border="1" data-bbox="539 1388 1133 1921"> <thead> <tr> <th>Gewählter Prozentsatz</th> <th>Menge (ml)</th> <th>Durchführbare Zyklen*</th> </tr> </thead> <tbody> <tr> <td>1%</td> <td>60</td> <td>≈25</td> </tr> <tr> <td>2%</td> <td>120</td> <td>≈12</td> </tr> <tr> <td>3%</td> <td>180</td> <td>≈8</td> </tr> <tr> <td>4%</td> <td>240</td> <td>≈6</td> </tr> <tr> <td>5%</td> <td>300</td> <td>≈5</td> </tr> <tr> <td>6%</td> <td>360</td> <td>≈4</td> </tr> </tbody> </table> <p><i>*Mit vollem Behälter (1500 ml)</i></p>	Gewählter Prozentsatz	Menge (ml)	Durchführbare Zyklen*	1%	60	≈25	2%	120	≈12	3%	180	≈8	4%	240	≈6	5%	300	≈5	6%	360	≈4	<table border="1" data-bbox="1236 1400 1380 1904"> <thead> <tr> <th>%</th> <th>Sek</th> </tr> </thead> <tbody> <tr> <td>1</td> <td>80</td> </tr> <tr> <td>2</td> <td>160</td> </tr> <tr> <td>3</td> <td>240</td> </tr> <tr> <td>4</td> <td>320</td> </tr> <tr> <td>5</td> <td>400</td> </tr> <tr> <td>6</td> <td>480</td> </tr> </tbody> </table>	%	Sek	1	80	2	160	3	240	4	320	5	400	6	480
Gewählter Prozentsatz	Menge (ml)	Durchführbare Zyklen*																																				
1%	60	≈25																																				
2%	120	≈12																																				
3%	180	≈8																																				
4%	240	≈6																																				
5%	300	≈5																																				
6%	360	≈4																																				
%	Sek																																					
1	80																																					
2	160																																					
3	240																																					
4	320																																					
5	400																																					
6	480																																					

<p>3</p>		<p>Erhitzung</p> <p>Das Gerät fährt 5 Minuten lang mit der Erhitzung und einer ersten Dekontaminierung der Instrumente fort. Wird die Temperatur nicht erreicht, wird die Erhitzung auch während des Waschgangs fortgesetzt.</p>	<p>5 Min¹</p>
<p>4</p>	 <p>BLINKEND</p>	<p>Entgasung (DEGAS)</p> <p>Das Gerät fährt 5 Minuten lang mit der intermittierenden Aktivierung der Ultraschalle fort. Dieses Verfahren reduziert die sich in der Flüssigkeit aufgelösten Gase und verbessert die Leistung des nachfolgenden Waschgangs.</p>	<p>5 Min¹</p>
<p>4S</p>	<p>DRÜCKEN START ZU WEITERGEHE N</p>	<p>STANDBY</p> <p>Diese erneuernde Phase erlaubt, wichtige Verfahren zu führen wie z. B.</p> <ul style="list-style-type: none"> - Die Instrumente im Waschmittel zu halten - Instrumente zu zufügen (BIS MAX 1 KG EDELSTAHLINSTRUMENTE) <p>UM DIE BETRIEBSBEREITSCHAFTSPHASE ZU VERLASSEN, UND DAS ZYKLUS AUTOMATISCH FERTIGZUMACHEN, DRÜCKEN SIE DEN DRUCK START.</p>	
<p>5</p>		<p>Ultraschallreinigung</p> <p>Reinigungsphase durch Ultraschall-Kavitation.</p> <p>SWEEP</p> <p>Die Ultraschalle werden in Frequenz moduliert und durch Reduzierung der negativen Auswirkungen der stationären Wellen verbessern sie die Verteilung der Ultraschall-Energie in der Waschflüssigkeit.</p> <p>Die Reinigung ist wirksamer (verbessert die Kavitation)</p>	<p>von 1 Min bis 30 Min</p>
<p>6</p>		<p>Abfluss</p> <p>Die Wanne wird automatisch geleert</p>	<p>≈ 1.5 Min</p>

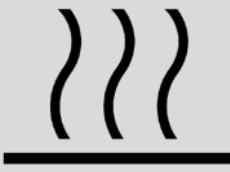
7		Zweites Einfüllen des Wassers Die Wanne wird erneut zum Abspülen der Instrumente gefüllt	1.5 Min (P Eintritt = 2.5 bar)
8		Ultraschall-Spülgang Aktivierung für eine kurze Zeit der Ultraschalle, Abspülen durch Kavitation.	1 Min
9		Abfluss Die Wanne wird automatisch geleert	≈ 1.5 Min
10		Trocknung Um die Instrumente zu trocknen, erzeugt die Maschine einen Warmluftstrom, der die Gegenstände streift und die Feuchtigkeit in Form von Dampf entfernt.	15 Min

Anmerkungen:

1 Wenn beide, die Erhitzungs- und die Entgasungsphase, eingestellt sind, werden sie gleichzeitig durchgeführt und dauern insgesamt 5 Minuten.

7.1 Steuerbrett

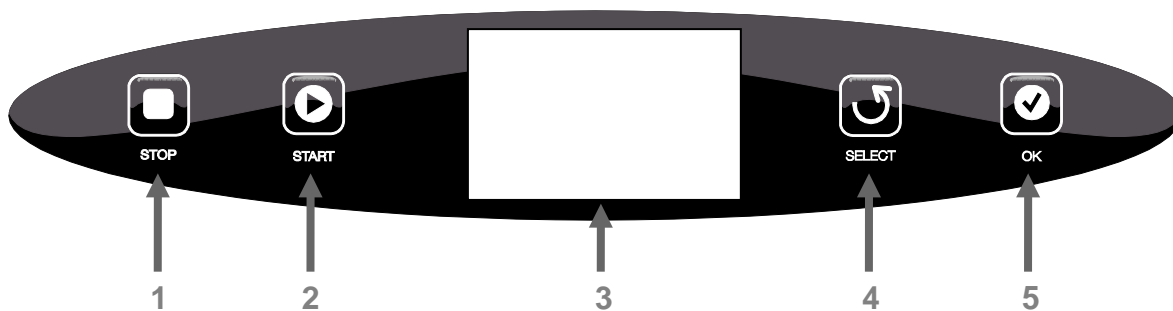

TASTEN FÜR START/UNTERBRECHUNG ZYKLUS

1	STOP – ANNULLIERT DEN ZYKLUS IN DURCHFÜHRUNG
2	START - ZYKLUSSTART

PROGRAMMIERTASTEN

4	SELECT - NAVIGATIONSTASTE
5	OK – DIE WAHL BESTÄTIGEN UND ZUM NÄCHSTEN ABSCHNITT ÜBERGEHEN
3	DISPLAY

7.2 Sprachenwahl

8 Sekunden lang **STOP** drücken.

Das Display zeigt die eingestellte Sprache an.

SELECT drücken und durch die verfügbaren Sprachen gleiten.

OK drücken und die gewählte Sprache bestätigen.

7.3 Zykluswahl

Beim Einschalten werden das Herstellerlogo und die Firmwareversion auf dem Display angezeigt.

Nach Ablauf von 3 Sekunden zeigt das Display Folgendes an:

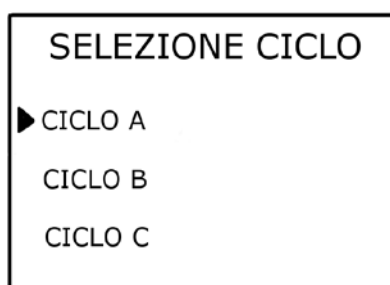

Zum Durchblättern der Programme **SELECT** drücken.

Zum Start des gewählten Zyklus **START** drücken.

7.4 Standardeinstellung der Zyklen

Das Gerät wird mit den folgenden Werkseinstellungen ausgeliefert:

	A	B	C
Standby	ON	OFF	OFF
Reinigungsmitteldosierung	1 %	1 %	1 %
Erhitzung	ON	OFF	ON
Funktion Degas	JA	JA	JA
Funktion SWEEP	NEIN	JA	NEIN
Ultraschallreinigung	20 Min	20 Min	5 Min
Trocknung	JA	JA	JA

Die Einstellungen können für alle Zyklen nach Belieben geändert werden.

7.5 Änderung der Zyklen

Den Zyklus wählen, den Sie ändern möchten.
 Zur Anzeige des MENÜS die Taste **OK** drücken.
 Verfügbare Einstellungen:

Beschreibung	Einstellungen	Step
Standby	ON - OFF	-
Reinigungsmitteldosierung	0 ÷ 6 %	1%
Erhitzung	ON - OFF	-
Funktion Degas	JA - NEIN	-
Funktion SWEEP	JA - NEIN	-
Ultraschallreinigung	0 ÷ 30 Min	1 Min
Trocknung	JA - NEIN	-

Zum Durchblättern der Zyklusparameter die Taste **OK** drücken.
 Zur Änderung des gewählten Parameterwerts die Taste **SELECT** drücken.
Sie können das Parameter- und Einstellungsmenü im Kreis durchblättern.
 Nach abgeschlossenen Einstellungen EXIT wählen und zum Verlassen des MENÜS **SELECT** drücken.

Die Änderungen werden gespeichert.

7.6 Einstellung STARTVERZÖGERUNG:

8 Sekunden lang **START** drücken.
 Um zum Durchlauf der Werte von 1 bis 9 Stunden überzugehen, **SELECT** drücken.
 Zur Einschaltung des verzögerten Starts **START** drücken.
 Während der Wartezeit wird ein Timer zur Anzeige der Zeit bis zum Zyklusstart angezeigt.
ACHTUNG: Bei Spannungsausfall wird der verzögerter Start annulliert.

GEBRAUCHSANLEITUNG

Den Wasserzufuhrhahn öffnen. Kontrollieren, dass sich der Filter in der Wanne befindet und diese sauber ist. Die zu behandelnden Gegenstände in das entsprechende KÖRBCHEN legen, bei kleinen Gegenständen das entsprechenden, mitgelieferten FRÄSENKÖRBCHEN verwenden.

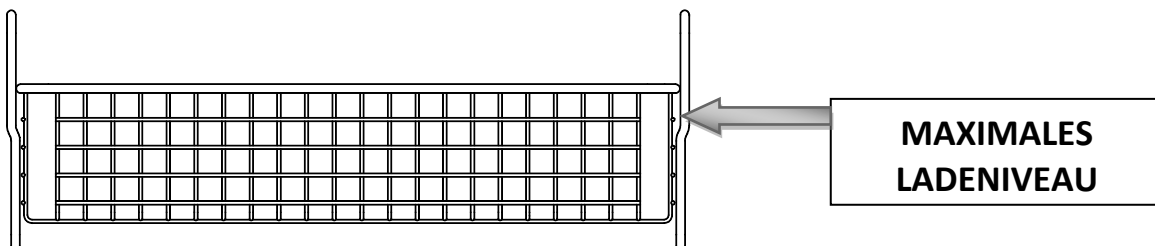

Die zu reinigenden Gegenständen müssen gleichmäßig verteilt eingeladen werden und dürfen nicht die Wände oder den Boden der Wanne berühren.
Das Körbchen in die Wanne stellen und dabei darauf achten, dass kein Kontakt zwischen den Wänden der Wanne und dem Körbchen besteht.

Es ist wichtig, dass Zement, Alginate und Mischungen mit spezifischen Flüssigkeiten vorbehandelt werden.

Wenn die Gegenstände groben Schmutz vorweisen, muss dieser vor der Positionierung der Instrumente im Körbchen entfernt werden, um die Verstopfung des Abflussfilters zu vermeiden. Zum Ausschluss des Kontakts zwischen den Stahlfüßchen des Körbchen und der Reinigungswanne aus Stahl werden entsprechende Gummiringe eingeführt. Wenn diese beschädigt sein oder fehlen sollten, neue Gummiringe einsetzen. Der falsche Gebrauch kann die Wanne beschädigen. Die Maschine mit dem entsprechenden Schalter (L) einschalten. Den gewählten Zyklus durch Druck von **START** einschalten, die Maschine zeigt die Zyklusphase, die sie ausführt, und den Countdown der Zeit (geschätzte Zeit) an, die für die Beendigung des Zyklus erforderlich ist.

Wenn das Zyklus erfordert die STANDBY – Phase, drücken Sie noch einmal den Druck **START** nach der Wasser-, und Reinigungsmittelseingang, nach der Entgasung und nach der Heizung). Das ermöglicht die Wasch-Phase anzufangen, und das angegebene Zyklus zu beenden.

Am Zyklusende wird ' **END CYCLE OK** ' angezeigt, gleichzeitig ertönt ein Signal. **OK** drücken, um zur Zykluswahl zu gelangen.

Wenn die Klappe mit laufendem Gerät geöffnet wird, blockiert dies automatisch den durchgeführten Prozess. Durch Schließen des Deckels nimmt der Zyklus genau an der Stelle, an der er unterbrochen wurde, den Betrieb wieder auf.



Am Ende eines Tages den oberhalb des Gerät installierten Hahn schließen.



Die Gegenstände, den Deckel und den Widerstand nicht während der Trocknung berühren. Verbrennungsgefahr.



Lassen Sie den Tank komplett entleeren, bevor Sie mit einem neuen Reinigungsmitteltyp den Tank einfüllen.

Gebrauch von einem anderen Reinigungsmitteltyp

Man kann ein anderes Reinigungsmitteltyp verwenden.

Im Menü des auszuführenden Zyklus bezüglich des automatischen Reinigungsmittelintritts ‚NEIN‘ einstellen.

Den Zyklus starten, nach wenigen Minuten (am Ende der Wassereinfüllphase) ertönt ein akustisches Signal, jetzt kann der Deckel geöffnet und der gewünschte Reinigungsmittelprozentatz (1% - 60 ml) direkt in die Wanne gegeben werden.

Den Deckel zur Beendigung des Zyklus schließen.

Reinigungsmitteltankentleerung

Wenn das Gerät die Nachfüllung vom Reinigungsmittel tank fordert, und Sie möchten zuerst den Tank komplett entleeren, dann drücken Sie die Taste **SELECT** und gleichzeitig die Taste **OK**.

Nach 5 Sekunden schaltet sich die peristaltische Pumpe ein, in dieser Phase ist ein intermittierendes Tonsignal zu hören, das sich erst am Ende dieser Phase ausschaltet, das Reinigungsmittel wird mithilfe der auf dem Deckel (I) angebrachten Düse in die Wanne abgelassen.

Nach circa 10 Min den Deckel etwas öffnen (ohne den Sensor für Deckelöffnung auszulösen) und kontrollieren, dass kein Reinigungsmittel aus der Düse austritt.

Am Ende der Entleerung, den Prozess mit der Taste **STOP** abrechnen.

9

WARTUNG

9.1 Reinigung

Die Reinigung muss am kalten Gerät und mit herausgezogenem Netzkabel vorgenommen werden.



Milde Reinigungsmittel für Kunststoff verwenden



Geeignete Reinigungsmittel für Edelstahl verwenden

9.2 Reinigung der Wanne



Die Sauberkeit der Wanne nach jedem Zyklus überprüfen

Eventuelle Ablagerungen oder Schutt entfernen, um die Einleitung von Materialien, die Verstopfungen verursachen können, in den Abflusskreislauf zu vermeiden.

9.3 Reinigung des Wannensfilters



Die Sauberkeit des Wannensfilters nach jedem Zyklus überprüfen

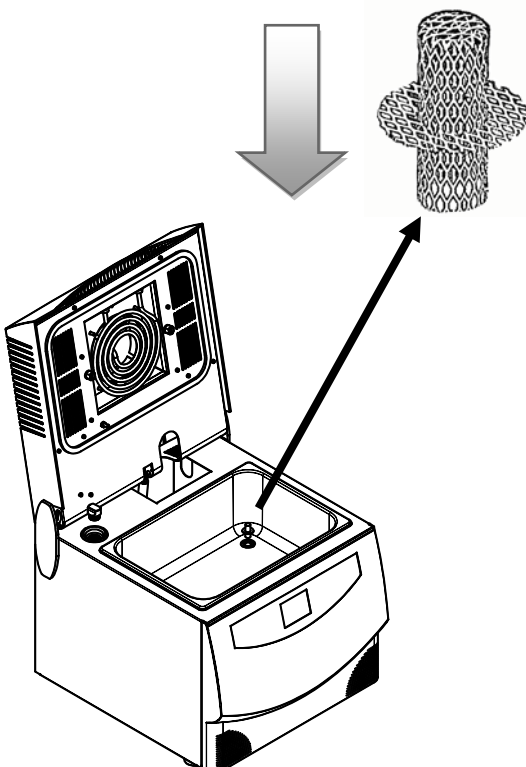

Den Deckel der Maschine anheben;

Die in der Wanne befindlichen Rückstände entfernen.

Den in der Wanne befindlichen Metallfilter, wie auf der Abbildung gezeigt, durch nach oben Ziehen herausnehmen;

Den Filter unter fließendem Wasser waschen, um alle vorhandenen Unreinheiten zu entfernen.

Den Filter erneut in seinem Sitz positionieren und dabei darauf achten, dass der offene Filterteil in den Abflussanschluss eingeführt wird und der geschlossene Teil in der Wanne sichtbar ist.

9.4 Reinigung des Wassereintrittfilters

Regelmäßig kontrollieren

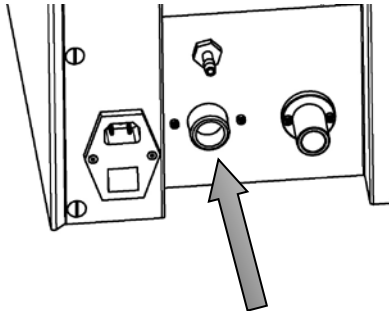

Die Wasserversorgung schließen, den Wasserzuleitungsanschluss entfernen und kontrollieren, dass der Filter (O) sauber ist.

Andernfalls ihn mithilfe einer Zange ohne Kraftaufwand herausnehmen und mit Wasser reinigen.

Den Filter und den Zuleitungsanschluss erneut montieren.

9.5 Niveausondereinigung

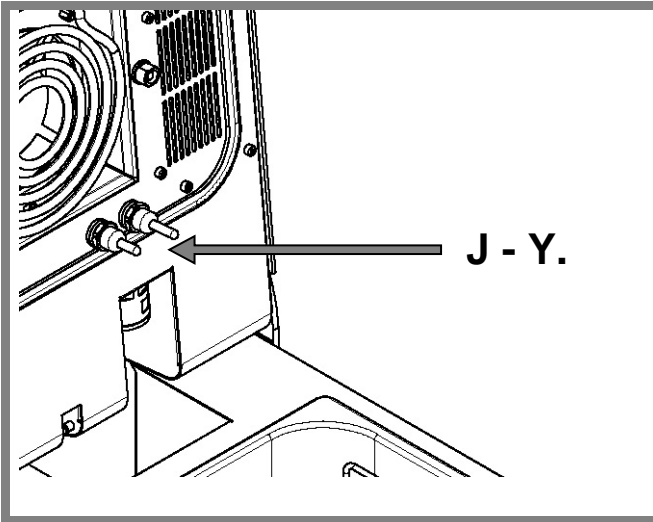

Überprüfen Sie regelmäßig die PROBE J - Y.

Reinigen Sie den Metallteil mit einem für Edelstahl geeigneten Reinigungsmittel oder mit einem ätzenden.

Verwenden Sie einen Schwamm (leicht abrasiv).

9.6 Programmierte Wartung



Ausschließlich Original-Ersatzteile verwenden

Beschreibung	Häufigkeit	Ausführende Person
Auswechslung Schlauch peristaltische Pumpe.	Jährlich	Ermächtigte Techniker
Kontrolle Laufrad für Trocknung	Jährlich	Ermächtigte Techniker
Wannenfilter	Bei Bedarf	Benutzer
Dichtung Verschluss Reinigungsmittel	Bei Bedarf	Benutzer
Deckeldichtung	Bei Bedarf	Ermächtigte Techniker



Die **Wartungs- und Reparaturarbeiten** müssen an der vom Stromnetz abgetrennten Maschine vorgenommen werden.

Eine richtige Gerätewartung gewährleistet den einwandfreien Betrieb und eine sichere Ersparnis bei Zeit und durch Kundendienst bedingten Kosten.

10

SIGNALS - FEHLER

10.1 Signale



Display	Ursache	Abhilfe
	Der Deckel steht offen.	Den Deckel schließen.
	Ungenügend flüssiges Reinigungsmittel im Behälter (≤ 0.5 l)	Den Reinigungsmittelbehälter auffüllen und den Zyklus neu starten oder einen reinigungsmittelfreien Zyklus einstellen
	Reinigungsmittelbehälter voll.	Das Auffüllen des Reinigungsmittelbehälters abbrechen. Bei Fortsetzung des Auffüllens tritt das Reinigungsmittel aus dem hinteren Schlauch des Überlaufs aus.

10.2 Fehler

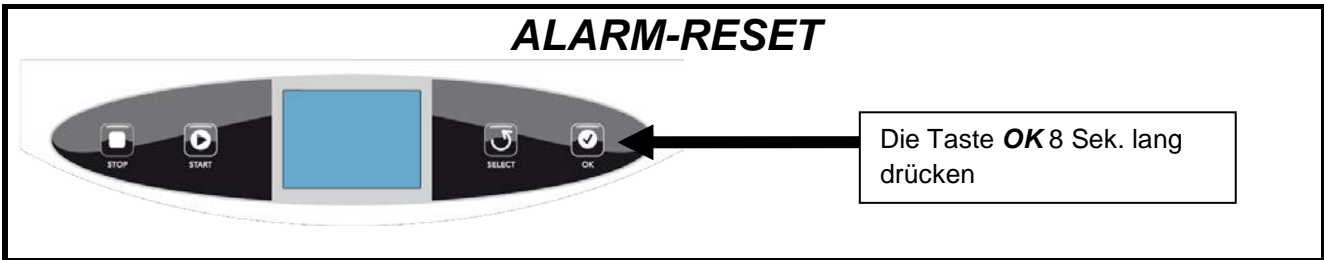
Bei einem Fehlersignal muss das Gerät rückgestellt werden, damit ein neuer Zyklus gestartet werden kann.

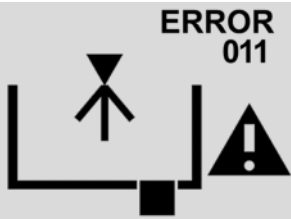

Display	Ursachen	Abhilfen
<p>ERROR 005</p>	<p>Störung Wassereintritt</p> <ul style="list-style-type: none"> - Hahn geschlossen - Filter verstopft - Störung beim Druck im Wassernetz 	<ul style="list-style-type: none"> - Kontrollieren, dass der Hahn geöffnet ist. - Das Wassereintrittsfilter reinigen. - Kontrollieren, dass sich der Wasserdruck in den angegebenen Grenzwerten befindet. Wenn unzureichend, einen Klempner zu Rate ziehen und die möglichen Abhilfen erwägen. - Kontrollieren, dass die Vorrichtung Water Block (ZUBEHÖR) nicht blockiert ist. - Prüfen, dass sich kein Wasser in der Wanne befindet und einen neuen Zyklus starten
<p>ERROR 010</p>	<p>Störung Wasserstand</p> <ul style="list-style-type: none"> - Das Gerät wurde während der Reinigung verschoben oder geneigt. - Es wurden viele Instrumente nach dem Wassereinlauf hinzugefügt. 	<ul style="list-style-type: none"> - Prüfen, dass sich kein Wasser in der Wanne befindet und den Zyklus neu starten. - Während des Zyklus keine Instrumente hinzufügen.
<p>ERROR 008</p>	<p>Störung Wasserabfluss</p> <ul style="list-style-type: none"> - Filter verstopft. - Bruch der Entleerungspumpe 	<ul style="list-style-type: none"> - Wannenfilter reinigen. - Prüfen, dass sich kein Wasser in der Wanne befindet und einen Zyklus neu starten.

Display	Ursachen	Abhilfen
	<p>Störung Wassereintritt</p>	<p>PROBE J e Y Reinigen Sie den Metallteil mit einem für Edelstahl geeigneten Reinigungsmittel oder mit einem ätzenden. Verwenden Sie einen Schwamm (leicht abrasiv).</p>
	<p>Störung Wassereintritt Störung beim Druck im Wassernetz</p>	<p>PROBE J e Y Reinigen Sie den Metallteil mit einem für Edelstahl geeigneten Reinigungsmittel oder mit einem ätzenden. Verwenden Sie einen Schwamm (leicht abrasiv). Kontrollieren, dass sich der Wasserdruck in den angegebenen Grenzwerten befindet. Wenn unzureichend, einen Klempner zu Rate ziehen und die möglichen Abhilfen erwägen.</p>

AUS DER WANNE WASSER ENTNEHMEN
ABFLUSSWASSERPUMPE FÜR 30 SEKUNDEN BETÄTIGEN



Die Taste **OK** 8 Sek. lang drücken

10.4 | Allgemeine Probleme

Probleme	Mögliche Ursachen	Abhilfe
Ungenügende Reinheit	- Kalkhaltiges Wasser, weiße Streifen auf den Instrumenten	- Oberhalb einen Wasserenthärter installieren. - Einige Reiniger können dieses Phänomen reduzieren
	- Unbehandelte Instrumente vorhanden (Zemente, Alginate)	- Mit geeigneten Reinigungsmitteln vorbehandeln.
	- Falsche Zykluseinstellungen	- Die Parameter ändern und die Reinigungszeit erhöhen.
	- Kein Geräusch der Ultraschalle während der Waschphase	- Sich an den technischen Kundendienst wenden
Ungenügende Trocknung	- Zu viel eingeladen, Tropfen zwischen den Instrumenten vorhanden	- Weniger einladen
	- Falsche Installation, eine geringe Wassermenge nach dem Abfluss auf dem Wannenboden vorhanden.	- Das Gerät richtig positionieren, die Höhe der Füße ändern
	- Kein Luftzug aus den Seitenschlitzen des Deckels	- Sich an den technischen Kundendienst wenden
Einige Instrumente werden beschädigt	- Für die Ultraschallreinigung ungeeignete Instrumente (z.B. Spiegelchen)	- Ungeeignete Instrumente nicht mit Ultraschall reinigen

Bei Störung oder Revision wenden Sie sich direkt an den telefonischen Kundendienst .

PHONE	+39 0521 8380
FAX	+39 0521 833391
@	service@tecnogaz.com

Der Kundendienst erwägt die Einsendung an den Sitz oder den Eingriff eines Technikers und er erstellt nach Inaugenscheinnahme der Maschine einen Kostenvoranschlag, der an den Händlerkunden gesandt wird, welcher ihn dem Endkunden zur Kenntnisnahme und Unterzeichnung übermittelt.

Nach Erhalt des zur Annahme unterzeichneten Voranschlags wird der Autoklav in Arbeit genommen und in den im Voranschlagsvordruck angegebenen Zeiten zugesandt.

Wenn der Autoklav an den Sitz eingeschickt werden muss, die folgenden obligatorischen Angaben befolgen:

- Die Original-Verpackung verwenden, wenn Sie diese nicht mehr besitzen, eine geeignete Verpackung verwenden. Die Ware reist auf Gefahr des Absenders.
- Nur die Multifunktionswanne einsenden (kein Teil aus dem Zubehör-Kit hineinlegen).
- Vor dem Versand die Wanne insgesamt sorgfältig reinigen. Sollte sie schmutzig und mit Rückständen eintreffen, wird die Wanne unrepariert zurückgeschickt oder einer Reinigung und Desinfizierung unterzogen.
- Den Reinigungsmittelbehälter immer entleeren.
- Schriftlich angeben und ein Dokument in die Verpackung legen, in dem Sie genau die festgestellte Störung oder den Service, der in Anspruch genommen werden soll, angeben.
- Immer frachtfrei versenden, andernfalls werden die getragenen Versandkosten in Rechnung gestellt.

Alle bei uns eingehenden Nichtoriginal-Verpackungen werden entsorgt.

Die Maschine wird in Original-Verpackung (die Kosten der Verpackung werden in Rechnung gestellt) mit Frachtführer des Kunden zurückgeschickt.

A

ZUBEHÖRTEILE

	BESCHREIBUNG	CODE
	KÖRBCHEN (180 mm X 280 mm H60 mm)	DVMA069
	DICHTUNGEN FÜR FÜSSCHEN	DFAA493
	FRÄSENKÖRBCHEN (D 70 mm H 60 mm)	DVMA072
	ZUFUHRSCHLAUCH (L 3 m)	CPLA002
	ABFLUSSSCHLAUCH (L 0.8-2.7 m)	CPLA001
	NETZKABEL (L 2.5 m)	CECG006
	TRICHTER	CPMG001
	WATER BLOCK (ZUBEHÖR)	DVMA092
	WANNENFILTER	DVMA115
	LAGENGESTELL (ZUBEHÖR)	VM801ZVM
	N°1 LAGEN (ZUBEHÖR)	SVMA070
	REINIGUNGS- BZW. DESINFEKTIONSMITTEL VERDÜNNUNGSPROZENTEIL FÜR ULTRASCHALLREINIGUNG: 1 % 1,0 L FLASCHE IN 6ER PACK	DM401ALP

B ZEICHNUNGEN

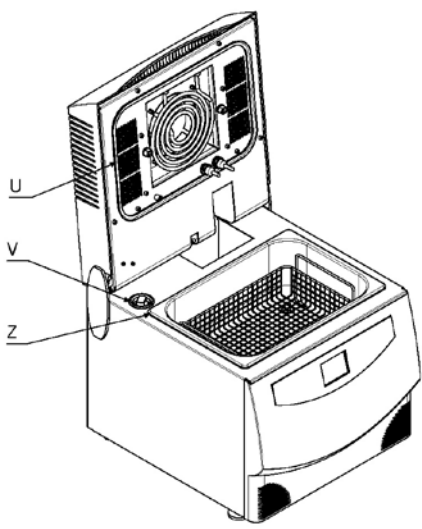
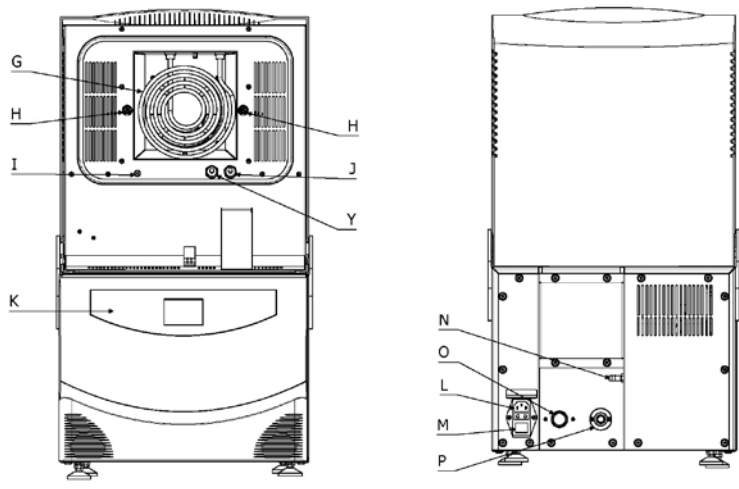
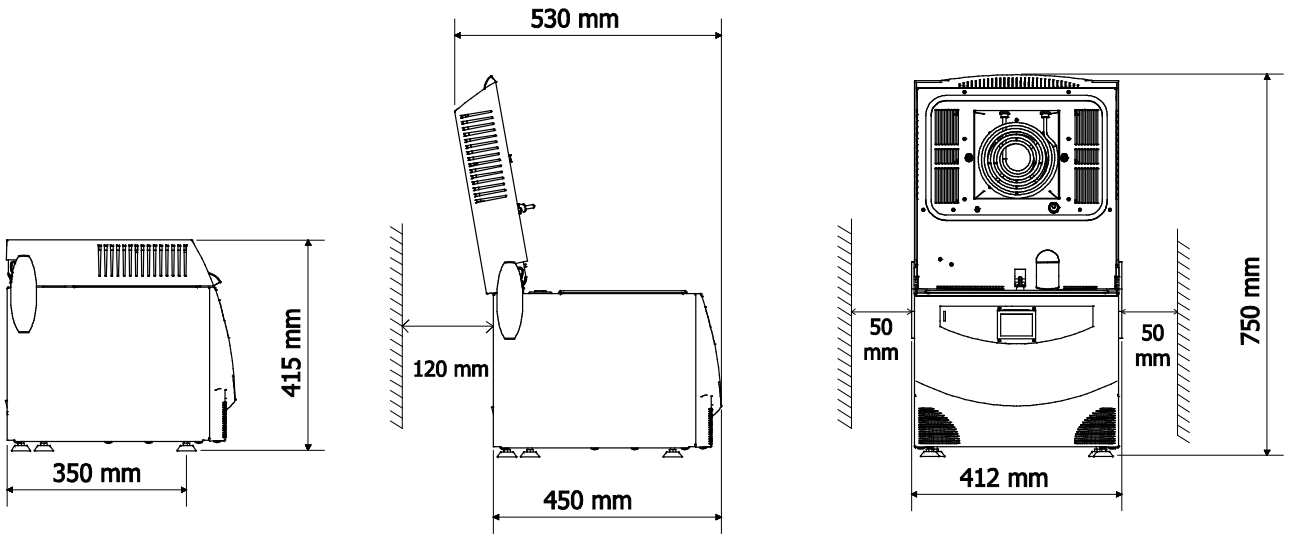

NDICE

- 1. USO Y EMPLEO DEL DISPOSITIVO**
- 2. SEGURIDAD**
 - 2.1 MARCADO DE SEGURIDAD
 - 2.2 DISPOSITIVOS DE SEGURIDAD
 - 2.3 ELIMINACIÓN
- 3. DATOS TÉCNICOS**
- 4. DESEMBALAJE**
- 5. COMPONENTES**
- 6. INSTALACIÓN**
 - 6.1 CONEXIONES
 - 6.2 LLENADO DEPÓSITO DETERGENTE
- 7. FUNCIONAMIENTO DEL APARATO**
 - 7.1 TABLERO DE MANDOS
 - 7.2 SELECCIÓN DEL IDIOMA
 - 7.3 SELECCIÓN DEL CICLO
 - 7.4 CONFIGURACIÓN ESTÁNDAR DE LOS CICLOS
 - 7.5 MODIFICACIÓN DE LOS CICLOS
 - 7.6 CONFIGURACIÓN INICIO RETARDADO
- 8. INSTRUCCIONES DE USO**
- 9. MANTENIMIENTO**
 - 9.1 LIMPIEZA
 - 9.2 LIMPIEZA DE LA CUBA
 - 9.3 LIMPIEZA DEL FILTRO DE LA CUBA
 - 9.4 LIMPIEZA DEL FILTRO DE ENTRADA DEL AGUA
 - 9.5 LIMPIEZA DE LA SONDA DE NIVEL
 - 9.6 MANTENIMIENTO PROGRAMADO
- 10. AVISOS - ERRORES**
 - 10.1 AVISOS
 - 10.2 ERRORES
 - 10.4 PROBLEMAS GENERALES
- 11. PROCEDIMIENTOS PARA EL SERVICIO Y LA ASISTENCIA**
 - A. ACCESORIOS**
 - B. DIBUJOS**

1

USO Y EMPLEO

USO	La cuba multifunción ha sido desarrollada para remover los restos orgánicos e inorgánicos y para secar al instrumental utilizado en el sector medical, dental, estético y veterinario
------------	--

A través del proceso de deterción por ultrasonidos, el dispositivo permite realizar la limpieza de los puntos más difíciles de alcanzar mediante la limpieza manual, evitando asimismo los riesgos debidos a la manipulación de instrumentos contaminados.

El usuario puede configurar la memorización de 3 ciclos.

Las fases principales son:

DETERSIÓN	Fase que reduce de más del 90% el nivel de contaminación microbiana. Esta fase elimina los residuos de material orgánico e inorgánicos.
ACLARADO	Esta fase elimina los posibles restos de detergente presentes en la cuba.
SECADO	Tras el aclarado, es necesario realizar el secado de los dispositivos para evitar que los residuos de agua afecten el proceso de esterilización sucesivo.



La cuba multifunción deberá utilizarse sólo y exclusivamente para la limpieza de instrumentos y materiales compatibles con el sistema de lavado por ultrasonidos y, por lo general, sólo para los usos especificados por el fabricante.

2

SEGURIDAD

	No utilizar el aparato en atmósferas potencialmente explosivas.
	Mantener el aparato alejado de fuentes de calor o radiaciones electromagnéticas.
	El posicionamiento del aparato deberá permitir al operador acceder fácilmente al tablero de mandos y a la pantalla.
	La instalación eléctrica deberá estar realizada en conformidad con las leyes vigentes. Comprobar que la instalación sea adecuada a las características del dispositivo.
	Comprobar la integridad del cable de alimentación.
	No utilizar detergentes inflamables.
	No utilizar ácidos (por ej. HCl) ni cloruros en el interior de la cuba.
	Evitar siempre el contacto de los objetos con el fondo de la cuba.
	El fabricante se considera responsable del producto comercializado según lo establecido por las leyes vigentes. El fabricante <u>queda excluido de toda responsabilidad</u> del en el caso de manipulación del dispositivo, o parte de ello, <u>por personal no calificado o de uso de piezas de recambio no originales.</u>
	NO ABRIR EL APARATO. En caso de avería o riesgo de entrada de líquido en el aparato durante las operaciones de mantenimiento y limpieza del aparato mismo, desconectar el cable de alimentación eléctrica.
	No quitar la placa
	Antes de realizar cualquier tipo de intervención, desconectar el cable de alimentación de la toma de corriente.
	Respetar las indicaciones de la ficha de seguridad del líquido detergente utilizado.
	En situaciones específicas, los ultrasonidos pueden producir ruidos desagradables para el oído. Utilizar dispositivos de protección personal idóneos.

2.1 Marcado de seguridad

	<p>TENSIÓN PELIGROSA</p>
 <p>ATTENZIONE ATTENTION ATTENTION ACHTUNG</p> <p>ALTA TEMPERATURA HIGH TEMPERATURES TEMPERATURES ELEVÉES HOHE TEMPERATUR</p>	<p>ALTA TEMPERATURA</p>
	<p>CONEXIÓN DE TIERRA</p>

2.2 Dispositivos de seguridad

-) Sensor de apertura tapa
-) Termostatos de seguridad
-) Sistema de control de la carga de agua

2.3 Eliminación



Este producto es regulado por la directiva 2009/96/CE del Parlamento Europeo y del Consejo de la Unión Europea sobre residuos de aparatos eléctricos (RAEE). En los países que han adoptado esta directiva, el producto ha sido comercializado con fecha posterior al 12 de agosto de 2005 y no deberá eliminarse como residuo urbano no reciclable. Utilizar las instalaciones locales de recogida RAEE correspondientes para la eliminación del producto o realizar esta operación de acuerdo con las leyes vigentes.

3

DATOS TÉCNICOS

MECÁNICOS

Temperatura de funcionamiento	+5°C ÷ +30°C
Humedad relativa MÁX de 30°C	80%
Gálibo (LxHxP)	415 x 415 x 530 mm
Altura tapa abierta	750 mm
Ancho tapa abierta	530 mm
Peso (depósito vacíos)	20 kg

ELÉCTRICOS

Tensión alimentación	230 V a.c. +/-10 % monofásico
Potencia MÁX instalada	1 kW
Frecuencia	50 / 60 Hz
Cable de alimentación	2 + 1 x 1mm ²
Fusibles	6.3 A (5 x 20)

ULTRASONIDOS

Nº transductores	4
Frecuencia	39 KHz

ALIMENTACIÓN HÍDRICA

Presión agua	1.5 ÷ 2 Bar
Conductividad del agua	> 50 µS/cm
Temperatura MÁX	+30°C
Dimensiones tubo de alimentación	3/8 G / largo 3 m

CUBA

Volumen cuba	9 l (Acero inoxidable AISI 316)
Volumen carga agua	6 l

DEPÓSITO DETERGENTE

Volumen	1.5 l + 0.5 l (reserva)
---------	---------------------------

Ciclos con el depósito lleno	Porcentaje seleccionado	Ciclos realizables*
	1%	≈25
	2%	≈12
	3%	≈8
	4%	≈6
	5%	≈5
	6%	≈4

Material	Polietileno
----------	-------------

FILTROS

Filtro cuba	Acero inoxidable AISI 304
-------------	---------------------------

Proteger el embalaje de los golpes y manejarlo con cuidado para evitar vuelcos y caídas. El dispositivo está posicionado sobre un pallet de madera y envuelto en cartón ondulado con refuerzos internos de cartón.

Abrir el cartón ondulado, extraer las piezas de refuerzo y extraer el dispositivo utilizando las correas proporcionadas.



La manipulación del aparato deberá realizarse sólo a través de las correas. No elevar nunca el dispositivo desde el cuadro de mandos. Esta operación podría dañar el aparato.



Conservar el embalaje durante todo el periodo de la garantía. El fabricante no aceptará las devoluciones realizadas sin el embalaje original.



No utilizar aparatos que presenten daños evidentes debidos al transporte.



Retirar el embalaje y comprobar el estado del aparato.

CONTENIDO:

- **CUBA MULTIFUNCIÓN**
- **MANUAL DE USO:** Leer atentamente el manual y conservarlo en un lugar accesible a todos los operadores encargados del funcionamiento del dispositivo.
- **DECLARACIÓN DE CONFORMIDAD:** Guardar.
- **INFORME DE INSTALACIÓN – PRUEBAS Y CONDICIONES DE GARANTÍA:** A rellenar en el momento de la instalación de la máquina según las indicaciones especificadas en el documento.
- **GUÍA RÁPIDA DE USO:** Guardar cerca de la máquina.
- Tubo de alimentación hídrica
- Tubo de descarga
- Tubo de salida detergente
- Cable de alimentación
- Cesta estándar
- Cesta portafresas
- Detergente recomendado

05 DESCRIPCIÓN DE LOS COMPONENTES

Véase el Apéndice B -DIBUJOS

G	Resistencia secado
H	Boquillas agua
I	Boquilla detergente
J - Y	Sonda
K	Teclado y LCD
L	Interruptor general
M	Enchufe de alimentación con porta-fusibles
N	Salida depósito detergente con función de rebosadero
O	Entrada agua (3/8 G)
P	Racor descarga
R	Amortiguador de gas
U	Junta tapa
V	Colector detergente
Z	Cuba inoxidable



El aparato no deberá utilizarse en atmósferas potencialmente explosivas.



Mantener el aparato alejado de fuentes de calor o radiaciones electromagnéticas.



El posicionamiento del aparato deberá permitir al operador acceder fácilmente al tablero de mandos y a la pantalla.



La instalación eléctrica deberá estar realizada en conformidad con las leyes vigentes. Comprobar que la instalación sea adecuada a las características del dispositivo.

Abrir la tapa y extraer los accesorios contenidos en la cuba.

Posicionar sobre una superficie perfectamente horizontal, estable y resistente a cargas mínimas de **35 kg**. Los soportes del dispositivo pueden ser regulados y permiten realizar incluso regulaciones mínimas;



Debido a una pendiente incorrecta, podría permanecer en el fondo de la cuba una capa de agua, impidiendo el secado correcto.

El posicionamiento del dispositivo debe permitir al operador inspeccionar y limpiar fácilmente la cuba. El operador deberá tener acceso a la parte trasera del dispositivo para realizar la limpieza del filtro.

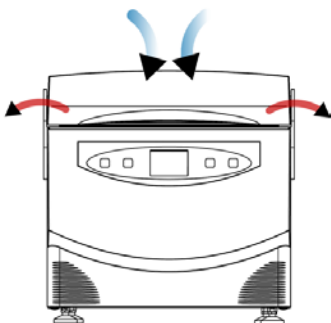

Durante la operación de secado, el dispositivo admite el aire desde la parte trasera y expulsa el aire caliente desde los lados.

Dejar un espacio mínimo de 50 mm en cada lado.

6.1 Conexiones

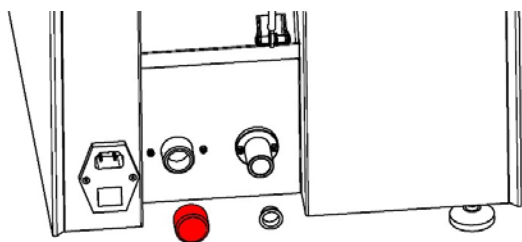

Quitar los tapones de protección.

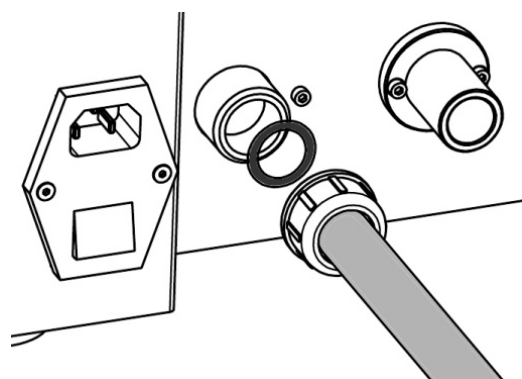

Tubo de carga del agua.

Conectar el tubo al dispositivo (O) introduciendo la junta de goma correspondiente. Conectar el otro extremo al grifo de alimentación.

OPCIONAL: sistema de bloqueo de emergencia del flujo de agua (WATER BLOCK). Este dispositivo deberá instalarse en posición inferior al grifo de alimentación y en posición vertical. Para más información acerca de la instalación y del uso del dispositivo, véase las instrucciones del dispositivo mismo.

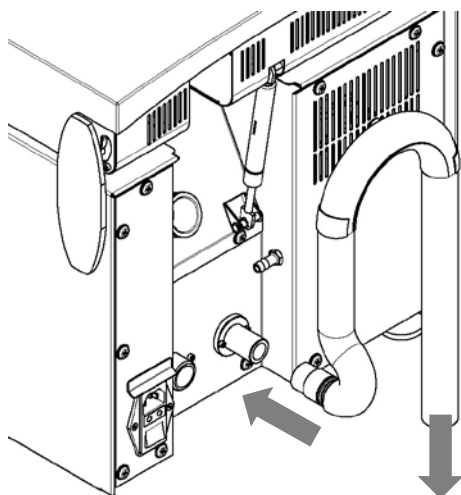

Tubo de descarga del agua.

Quitar el tapón de protección. Conectar el tubo al dispositivo (P). Conectar el otro extremo a la descarga. Fijar el tubo de forma estable y segura.



Instale el sifón como se muestra en la figura

Tubo de salida del depósito del detergente

Posicionar el tubo de salida transparente proporcionado en un punto visible, a la altura de la superficie de apoyo de la máquina o por debajo del mismo. No obstruir ni sumergir en el líquido. El tubo de salida también tiene función de rebosadero: si el depósito del detergente está lleno y se sigue introduciendo detergente, éste es descargado por el tubo de salida.

Cable de alimentación



Comprobar la integridad del cable de alimentación.

Conectar el cable de alimentación a la toma posicionada en la parte trasera del dispositivo (M).



No utilizar alargadores, reductores ni adaptadores

Encender la máquina utilizando el interruptor correspondiente (L).

Abrir el grifo de alimentación del agua y comprobar que el tubo de carga no presente pérdidas. En caso de pérdidas, apretar los racores y comprobar la instalación de las juntas. Comprobar la presencia y la limpieza del filtro en la cuba.

6.2 Llenado del depósito detergente:

El depósito dispone de una capacidad de aprox. 2 litros, de los cuales 0,5 litros se utilizan como reserva.

Durante el llenado, el dispositivo deberá estar encendido y mostrar el mensaje 'SELECCIÓN CICLO'.



ENCENDER SIEMPRE LA MÁQUINA ANTES DE REALIZAR EL LLENADO DEL DEPÓSITO DEL DETERGENTE

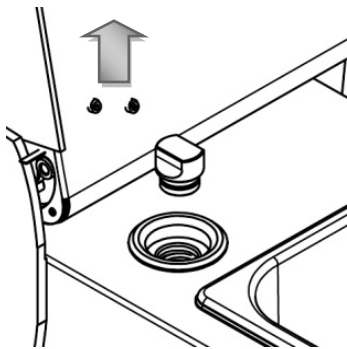

Abrir la tapa de la cuba y quitar el tapón (V) posicionado en el lado izquierdo de la cuba.

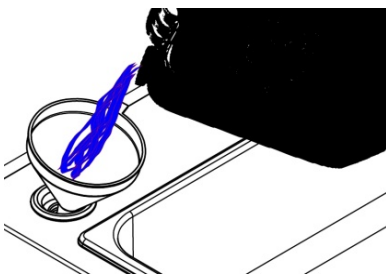

Introducir el líquido detergente (posiblemente utilizando el embudo proporcionado) hasta oír la señal acústica/visual (en la pantalla) de llenado del depósito.



Utilizar sólo los líquidos recomendados por el fabricante.



No realizar la mezcla de líquidos en el interior del depósito en cuanto podrían producirse reacciones químicas dañando gravemente el dispositivo.

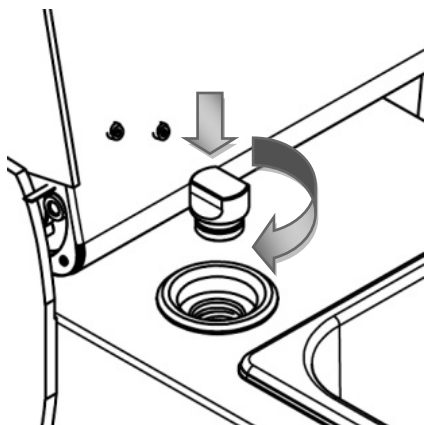

Presionar y girar ligeramente para cerrar el tapón de entrada detergente.



Es importante cerrar el tapón de entrada del detergente para evitar la cristalización del detergente mismo, lo cual podría producir obstrucciones y dañar los componentes.



7 FUNCIONAMIENTO DEL APARATO





El dispositivo multifunción dispone de una tapa que permite acceder a la cuba de lavado.

Posicionar en el interior de la cuba de lavado la cesta especial, equipada con soportes de goma, que contiene los objetos a limpiar.

El dispositivo multifunción dispone de un depósito interno de detergente que, durante el ciclo, dosifica e inyecta de forma automática el líquido en la cuba de lavado.

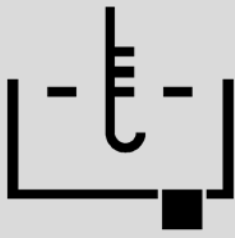
Un ciclo de lavado completo incluye las fases descritas en la tabla siguiente.

FASE	SÍMBOLO	DESCRIPCIÓN	DURACIÓN																																			
1		<p>Carga del agua</p> <p>El agua entra en la cuba superando de aprox. 2 mm el borde de la cesta.</p> <p>El volumen total es de aprox. 6 litros.</p>	<p>1.5 min</p> <p>(P entrada = 2.5 bar)</p>																																			
2		<p>Entrada detergente</p> <p>De forma automática, una bomba dosifica y transfiere, desde el depósito hasta el interior de la cuba, la cantidad de detergente configurada:</p> <table border="1" data-bbox="523 1205 1150 1742"> <thead> <tr> <th>Porcentaje seleccionado</th> <th>Volumen (ml)</th> <th>Ciclos realizables *</th> </tr> </thead> <tbody> <tr> <td>1%</td> <td>60</td> <td>≈25</td> </tr> <tr> <td>2%</td> <td>120</td> <td>≈12</td> </tr> <tr> <td>3%</td> <td>180</td> <td>≈8</td> </tr> <tr> <td>4%</td> <td>240</td> <td>≈6</td> </tr> <tr> <td>5%</td> <td>300</td> <td>≈5</td> </tr> <tr> <td>6%</td> <td>360</td> <td>≈4</td> </tr> </tbody> </table> <p><i>* Con el depósito lleno (1500 ml)</i></p>	Porcentaje seleccionado	Volumen (ml)	Ciclos realizables *	1%	60	≈25	2%	120	≈12	3%	180	≈8	4%	240	≈6	5%	300	≈5	6%	360	≈4	<table border="1" data-bbox="1238 1234 1382 1742"> <thead> <tr> <th>%</th> <th>seg</th> </tr> </thead> <tbody> <tr> <td>1</td> <td>80</td> </tr> <tr> <td>2</td> <td>160</td> </tr> <tr> <td>3</td> <td>240</td> </tr> <tr> <td>4</td> <td>320</td> </tr> <tr> <td>5</td> <td>400</td> </tr> <tr> <td>6</td> <td>480</td> </tr> </tbody> </table>	%	seg	1	80	2	160	3	240	4	320	5	400	6	480
Porcentaje seleccionado	Volumen (ml)	Ciclos realizables *																																				
1%	60	≈25																																				
2%	120	≈12																																				
3%	180	≈8																																				
4%	240	≈6																																				
5%	300	≈5																																				
6%	360	≈4																																				
%	seg																																					
1	80																																					
2	160																																					
3	240																																					
4	320																																					
5	400																																					
6	480																																					

3		<p>Calentamiento</p> <p>Durante 5 minutos el dispositivo realiza el calentamiento y una primera fase de descontaminación de los instrumentos.</p> <p>Si no fuera posible alcanzar la temperatura, la operación de calentamiento continúa durante la fase de lavado.</p>	5 min ¹
4	 <p>INTERMITENTE</p>	<p>Desgasificación (DEGAS)</p> <p>Durante 5 minutos, el dispositivo activa los ultrasonidos de forma intermitente. Este proceso reduce los gases disueltos en el líquido, mejorando así la eficacia del lavado.</p>	5 min ¹
4S	<p>PULSA START PARA CONTINUAR</p>	<p>STANDBY</p> <p>Esta nueva fase permite:</p> <ul style="list-style-type: none"> - Mantener los instrumentos en el líquido de lavado (REMOJO) - Añadir instrumentos (ATENCIÓN MAX 1 KG DE ACERO) <p>PARA SALIR DE LA FASE DE STANDBY Y TERMINAR EL CICLO AUTOMÁTICAMENTE ES NECESARIO PULSAR “START”</p>	
5		<p>Lavado por ultrasonidos</p> <p>Fase de lavado realizada mediante cavitación ultrasónica.</p> <p>SWEEP (BARRIDO)</p> <p>Los ultrasonidos son modulados en frecuencia, reduciendo los efectos negativos de las ondas estacionarias y aumentando la distribución de la energía ultrasónica en el líquido de lavado.</p> <p>De esta forma, se obtiene una limpieza más eficaz (mejor cavitación).</p>	de 1 min a 30 min
6		<p>Descarga</p> <p>La cuba se vacía automáticamente</p>	≈ 1.5 min

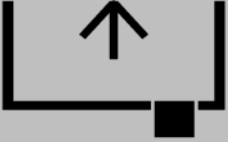
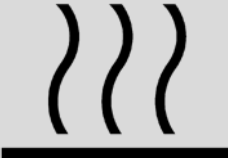
7		<p>Segunda carga del agua</p> <p>La cuba vuelve a ser llenada para realizar el enjuague los instrumentos</p>	<p>1.5 min (P entrada = 2.5 bar)</p>
8		<p>Enjuague con ultrasonidos</p> <p>Activación de los ultrasonidos durante un corto periodo, enjuague mediante cavitación.</p>	<p>1 min</p>
9		<p>Descarga</p> <p>La cuba se vacía automáticamente</p>	<p>≈ 1.5 min</p>
10		<p>Secado</p> <p>Para realizar el secado de los instrumentos, la máquina produce un flujo de aire caliente que elimina la humedad de los objetos convirtiéndola en vapor.</p>	<p>15 min</p>

Notas:

1 Si se han configurado ambas fases de calentamiento y desgasificación, éstas se realizarán simultáneamente, con una duración total de 5 minutos.

7.1 | Tablero de mandos

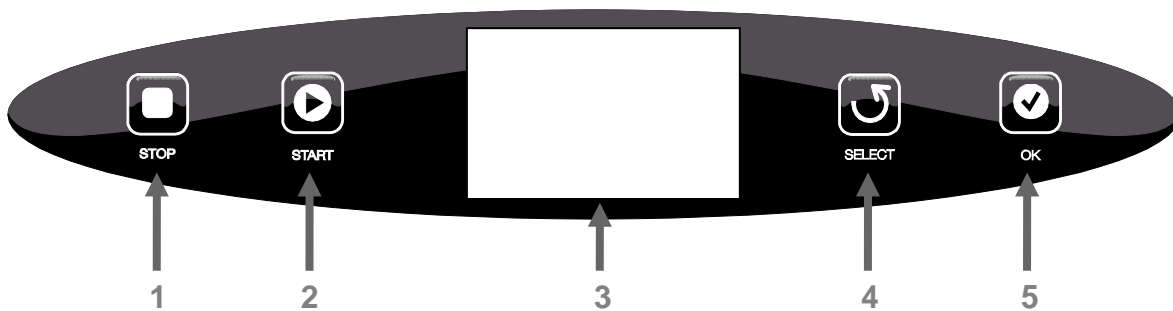

BOTONES DE INICIO/INTERRUPCIÓN DEL CICLO

1	STOP - ANULA LA EJECUCIÓN DEL CICLO ACTUAL
2	START - INICIA EL CICLO

BOTONES DE PROGRAMACIÓN

4	SELECT - BOTÓN DE NAVEGACIÓN
5	OK - CONFIRMA LA SELECCIÓN ACTUAL Y PASA A LA SECCIÓN SUCESIVA
3	PANTALLA

7.2 Selección del idioma

Presionar **STOP** durante 8 segundos.

La pantalla muestra el idioma configurado.

Presionar **SELECT** para visualizar los idiomas disponibles.

Presionar **OK** para confirmar el idioma seleccionado.

7.3 Selección del ciclo

Al encender el dispositivo, la pantalla muestra el logotipo del fabricante y la versión del firmware.

Después de 3 segundos la pantalla muestra lo siguiente:

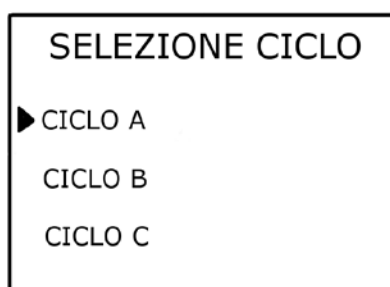

Presionar **SELECT** para visualizar los programas.

Presionar **START** para iniciar el ciclo seleccionado.

7.4 Configuración estándar de los ciclos

La configuración de fábrica del dispositivo es la siguiente:

	A	B	C
Standby	ON	OFF	OFF
Entrada detergente	1 %	1 %	1 %
Calentamiento	ON	OFF	ON
Función Degas	SÍ	SÍ	SÍ
Función SWEEP	NO	SÍ	NO
Limpieza por ultrasonidos	20 min	20 min	5 min
Secado	SÍ	SÍ	SÍ

Es posible personalizar los ajustes de todos los ciclos.

7.5 Modificación de los ciclos

Seleccionar el ciclo a modificar. Presionar el botón **OK** para visualizar el MENU.

Ajustes disponibles:

Descripción	Ajustes	Step
Standby	ON - OFF	-
Entrada detergente	0 ÷ 6 %	1%
Calentamiento	ON - OFF	-
Función Degas	SÍ - NO	-
Función SWEEP	SÍ - NO	-
Limpieza por ultrasonidos	0 ÷ 30 min	1 min
Secado	SÍ - NO	-

Presionar el botón **OK** para visualizar los parámetros del ciclo.

Presionar el botón **SELECT** para modificar el valor del parámetro seleccionado.

El menú de los parámetros y de los ajustes dispone de de desplazamiento cíclico.

Una vez completada la configuración, seleccionar EXIT y presionar **SELECT** para salir del MENU.

Los cambios serán guardados.

7.6 Configuración INICIO RETARDADO:

Presionar **START** durante 8 segundos.

Presionar **SELECT** para visualizar los valores de 1 a 9 horas.

Presionar **START** para activar el inicio retardado.

Durante la espera, un temporizador mostrará el tiempo restante antes del inicio del ciclo.

ATENCIÓN: En el caso de ausencia de tensión, el inicio retardado será anulado.

8

INSTRUCCIONES DE USO

Abrir el grifo de alimentación del agua. Comprobar la presencia del filtro en la cuba y su limpieza. Posicionar los objetos a limpiar en la CESTA correspondiente. En el caso de objetos pequeños, utilizar el PORTAFRESAS proporcionado.

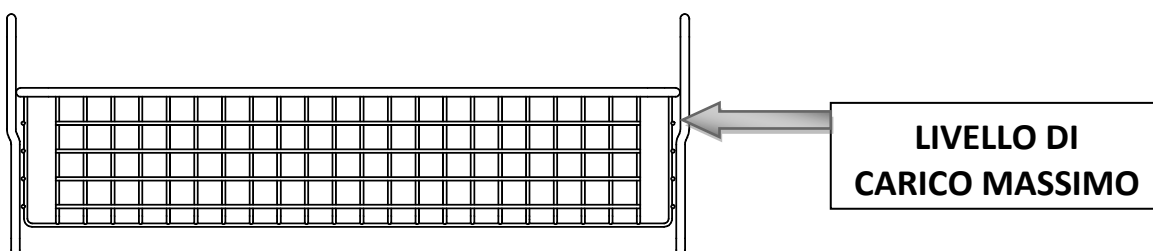

La carga deberá realizarse distribuyendo de forma homogénea los objetos a lavar: estos no deberán entrar en contacto con las paredes o el fondo de la cuba.

Introducir la cesta en el interior de la cuba evitando cuidadosamente el contacto entre las paredes de la cuba y la cesta.

Es importante pre-tratar los materiales como cemento, alginado y compuestos de líquidos específicos.



Si los objetos presentaran una suciedad excesiva, eliminarla antes de introducir los instrumentos en la cesta para evitar obstruir el filtro de descarga.

Para evitar el contacto entre las patas de la cesta de acero y la cuba de lavado de acero, se han introducido unas anillas especiales de goma. Introducir anillas nuevas en el caso de que éstas estuvieran dañadas o no disponibles. Un uso incorrecto puede dañar la cuba. Encender la máquina utilizando el interruptor correspondiente (L).

Activar el ciclo seleccionado presionando **START**. La máquina mostrará la fase del ciclo actual y la cuenta atrás del tiempo necesario (estimado) para el completamiento del ciclo. Si el ciclo incluye la fase de STANDBY será necesario pulsar la tecla **START** una segunda vez (después de las tapas de carga de agua, salida detergente, degas y calentamiento) para pasar a la tapa de lavado y terminar el ciclo.

Una vez finalizado el ciclo, el dispositivo mostrará el mensaje 'END CYCLE OK' y emitirá una señal acústica. Presionar OK para volver al menú de selección del ciclo.

En caso de apertura de la tapa durante el funcionamiento del dispositivo, el proceso en fase de ejecución será bloqueado de forma automática. Al cerrar la tapa, el ciclo se reanudará automáticamente a partir del punto de interrupción.

-  **Al finalizar el día de trabajo, cerrar el grifo instalado en posición superior al dispositivo.**
-  **No tocar los objetos, la tapa y la resistencia durante la fase de secado. Peligro de quemaduras.**
-  **Vaciar completamente el depósito antes de introducir un detergente diferente.**

Uso de un detergente diferente del líquido contenido en el depósito:

Es posible utilizar un detergente diferente de aquello contenido en el depósito.

En el menú del ciclo seleccionado, elegir 'NO' en correspondencia de la opción de entrada automática del detergente.

Iniciar el ciclo. Después de unos minutos (al completamiento de la fase de carga del agua), el dispositivo emitirá una señal acústica que indica que es posible abrir la tapa e introducir directamente en la cuba el porcentaje (1% - 60ml) deseado de detergente.

Cerrar la tapa para completar el ciclo.

Vaciado del depósito detergente:

Para vaciar completamente el depósito del detergente, utilizar el dispositivo y, cuando éste solicite la introducción de nuevo detergente, presionar y mantener presionado el botón **SELECT** y, al mismo tiempo, presionar y mantener presionado el botón **OK**.

Después de 5 segundos, la bomba peristáltica es accionada. Durante esta fase, el dispositivo emite una señal acústica intermitente que se interrumpe sólo al completamiento de la fase. El detergente es descargado directamente en la cuba a través de la boquilla posicionada en la tapa (I).

Después de aprox. 10 minutos, abrir ligeramente la tapa (sin activar el sensor de apertura tapa) y comprobar que no salga detergente de la boquilla.

Una vez finalizada la operación de vaciado, interrumpir el proceso presionando el botón **STOP**.

9

MANTENIMIENTO

9.1 Limpieza

Antes de realizar la limpieza, dejar enfriar el dispositivo y desconectar el cable de alimentación.



Utilizar detergentes no agresivos y adecuados para el plástico



Utilizar detergentes adecuados para el acero inoxidable

9.2 Limpieza de la cuba



Comprobar la limpieza de la cuba tras el completamiento de cada ciclo

Para evitar obstrucciones, eliminar los posibles restos o depósitos que podrían introducir material en el circuito de descarga.

9.3 Limpieza del filtro de la cuba



Comprobar la limpieza del filtro de la cuba tras el completamiento de cada ciclo

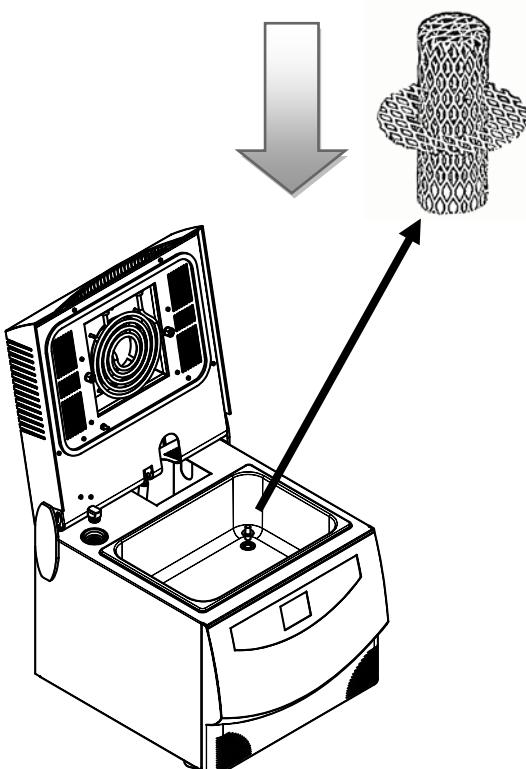

Abrir la tapa de la máquina;

Eliminar los residuos presentes en la cuba.

Extraer el filtro metálico presente en la cuba tirando hacia arriba, tal y como se indica en la figura;

Lavar el filtro con agua corriente para eliminar las impurezas.

Volver a posicionar el filtro en su alojamiento, teniendo cuidado para introducir la parte abierta del filtro dentro del racor de descarga y la parte cerrada girada hacia la cuba.

9.4 Limpieza del filtro de entrada del agua

Comprobar periódicamente

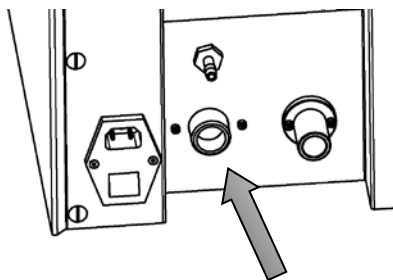

Cerrar la alimentación hídrica, extraer el tubo de carga del agua y comprobar que el filtro (O) esté limpio.

En caso contrario, extraer el filtro con una pinza, sin forzar. A continuación limpiar con agua.

Volver a montar el filtro y el tubo de alimentación.

9.5 Limpieza de la sonda de nivel

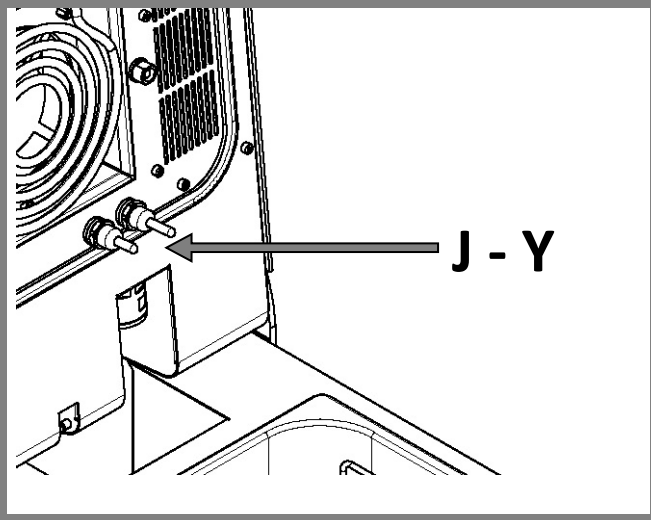

Limpieza de la sonda de nivel
 Compruebe periódicamente la **SONDA J - Y**.
 Limpie el metal con productos adecuados para el acero inoxidable o con un producto corrosivo
 Use una esponja (un poco abrasiva).

9.6 Mantenimiento programado

 **Utilizar sólo y exclusivamente recambios originales**



Descripción	Frecuencia	Operador
Sustitución tubo de la bomba peristáltica	Anual	Técnicos autorizados
Comprobación ventilador de secado	Anual	Técnicos autorizados
Filtro cuba	Si necesario	Usuario
Junta tapón del detergente	Si necesario	Usuario
Junta tapa	Si necesario	Técnicos autorizados

Antes de realizar las operaciones de **mantenimiento y reparación** comprobar que la máquina esté desconectada de la alimentación eléctrica.
 El mantenimiento correcto del dispositivo garantiza el buen funcionamiento del mismo y el ahorro de tiempo y dinero requeridos para la asistencia.

10

AVISOS - ERRORES

10.1 Avisos

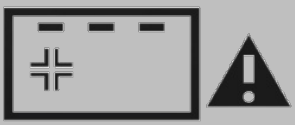

Pantalla	Causa	Solución
	La tapa está abierta.	Cerrar la tapa.
	El líquido detergente del depósito no es suficiente (≤ 0.5 l).	Llenar el depósito del detergente y reiniciar el ciclo o configurar un ciclo sin detergente.
	El depósito del detergente está lleno.	Interrumpir el llenado del depósito del detergente. Si no se interrumpe esta operación, el detergente saldrá a través del tubo rebosadero trasero.

10.2 Errores

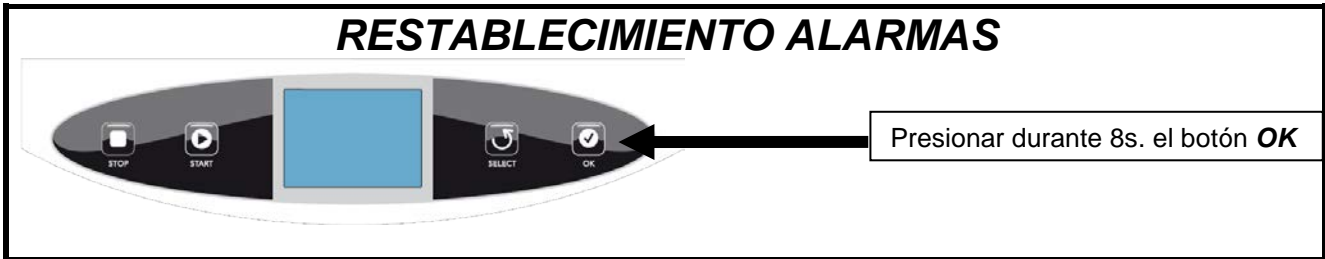
En caso de error, será necesario restablecer el dispositivo para poder iniciar un nuevo ciclo.

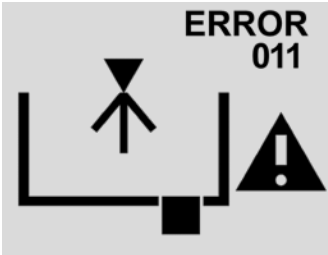

Pantalla	Causas	Soluciones
	<p>Anomalía entrada agua</p> <ul style="list-style-type: none"> - Grifo cerrado - Filtros obstruidos - Anomalía de la presión de la instalación hídrica 	<ul style="list-style-type: none"> - Comprobar que el grifo esté abierto. - Limpiar el filtro de entrada agua. - Comprobar que la presión hídrica respete los límites especificados. Si fuera insuficiente, consultar un fontanero para evaluar las soluciones posibles. - Comprobar que el Water Block (OPCIONAL) no esté bloqueado. - Comprobar que la cuba no contenga agua e iniciar un ciclo nuevo.
	<p>Anomalía nivel agua</p> <ul style="list-style-type: none"> - El dispositivo ha sido desplazado o inclinado durante el lavado - Ha sido añadido un número elevado de instrumentos después de la carga del agua 	<ul style="list-style-type: none"> - Comprobar que la cuba no contenga agua y reiniciar el ciclo. - No añadir instrumentos durante el ciclo.
	<p>Anomalía descarga agua</p> <ul style="list-style-type: none"> - Filtros obstruidos. - Rptura de la bomba de descarga 	<ul style="list-style-type: none"> - Limpiar el filtro de la cuba. - Comprobar que la cuba no contenga agua y reiniciar un ciclo.

Pantalla	Causas	Soluciones
	<p>Anomalía entrada agua</p>	<p>Limpeza de la SONDA J - Y.</p> <p>Limpe el metal con productos adecuados para el acero inoxidable o con un producto corrosivo</p> <p>Use una esponja (un poco abrasiva).</p>
	<p>Anomalía entrada agua Anomalía de la presión de la instalación hídrica</p>	<p>Limpeza de la SONDA J - Y.</p> <p>Limpe el metal con productos adecuados para el acero inoxidable o con un producto corrosivo</p> <p>Use una esponja (un poco abrasiva).</p> <p>Comprobar que la presión hídrica respete los límites especificados. Si fuera insuficiente, consultar un fontanero para evaluar las soluciones posibles.</p>

ELIMINAR EL AGUA EN LA CUBA
ENCENDER LA BOMBA DE DESCARGA PARA 30 SEGUNDOS



10.4 Problemas generales

Problemas	Causas posibles	Solución
Limpieza insuficiente	- Agua calcárea, marcas blancas en los instrumentos	- Instalar un ablandador en posición superior al dispositivo. - Algunos detergentes pueden solucionar parcialmente este problema.
	- Presencia de elementos no pre-tratados (cemento, alginado)	- Pre-tratar con detergentes idóneos.
	- Configuración incorrecta del ciclo	- Modificar los parámetros aumentando el tiempo de lavado.
	- No se percibe el ruido de los ultrasonidos durante la fase de lavado	- Contactar con el servicio de asistencia técnica.
Secado insuficiente	- Carga excesiva, presencia de gotas en los instrumentos	- Reducir la carga.
	- Instalación incorrecta, presencia de agua en el fondo de la cuba tras la operación de descarga	- Posicionar correctamente el dispositivo, modificar la altura de las patas.
Algunos instrumentos resultan dañados	- No se percibe la salida del flujo de aire desde las ranuras laterales de la tapa	- Contactar con el servicio de asistencia técnica.
	- Instrumentos no aptos para el lavado por ultrasonidos (ej. espejos)	- No someter a la limpieza por ultrasonidos los instrumentos no idóneos.

11 PROCEDIMIENTOS PARA EL SERVICIO Y LA ASISTENCIA

En el caso de avería o revisión, contactar directamente con la asistencia telefónica.

TEL	+39 0521 8380
FAX	+39 0521 833391
@	service@tecnogaz.com

La asistencia se encargará de evaluar la incidencia y establecerá si es necesario el envío del dispositivo o la intervención de un técnico. Una vez examinada la máquina, se proporcionará el presupuesto al cliente distribuidor, quien se encargará de enviarlo al cliente final para su información y firma.

Tras haber recibido el presupuesto firmado, el dispositivo será reparada y enviada según los tiempos especificados en el documento del presupuesto.

Si fuera necesario enviar el dispositivo al fabricante, realizar las siguientes operaciones obligatorias:

- Utilizar el embalaje original. Si este no estuviera disponible, utilizar un embalaje adecuado. El envío de la mercancía estará a cargo del remitente.
- Enviar sólo la cuba multifunción (no introducir ningún componente del kit de accesorios).
- Limpiar cuidadosamente la cuba antes de enviarla. En el caso de envío de cubas sucias y con residuos, el fabricante las reenviará sin reparar o, en caso contrario, la someterá a un tratamiento de limpieza y desinfección.
- Descargar siempre el depósito del detergente.
- Especificar por escrito e introducir en el embalaje un documento que describa exactamente la anomalía detectada o el servicio deseado.
- Enviar siempre libre de porte. En caso contrario, el cliente deberá abonar al fabricante los gastos de transporte.

Todos los embalajes no originales enviados serán desechados.

La máquina se enviará al cliente en su embalaje original (el coste del embalaje estará a cargo del cliente) mediante el transportista del cliente.

A

ACCESORIOS

	DESCRIPCIÓN	CÓDIGO
	CESTA (180 mm X 280 mm H60 mm)	DVMA069
	JUNTAS PATAS	DFAA493
	PORTAFRESAS (D 70 mm H 60 mm)	DVMA072
	TUBO DE CARGA (L 3 mt)	CPLA002
	TUBO DE DESCARGA (L 0.8-2.7 mt)	CPLA001
	CABLE DE ALIMENTACIÓN (L 2.5 mt)	CECG006
	EMBUDO	CPMG001
	WATER BLOCK (OPCIONAL)	DVMA092
	FILTRO CUBA	DVMA115
	PORTABANDEJA (OPCIONAL)	VM801ZVM
	Nº1 BANDEJAS (OPCIONAL)	SVMA070
	LÍQUIDO DETERGENTE/DESINFECTANTE DILUCIÓN PARA LA DETERSIÓN ULTRASÓNICA: 1% BOTELLA DE 1,0 L BULTO DE 6 BOTELLAS	DM401ALP

B

DIBUJOS

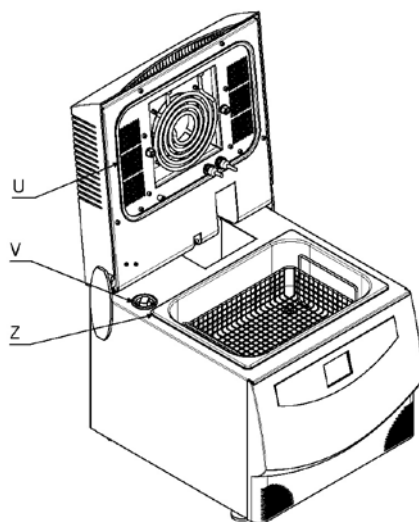
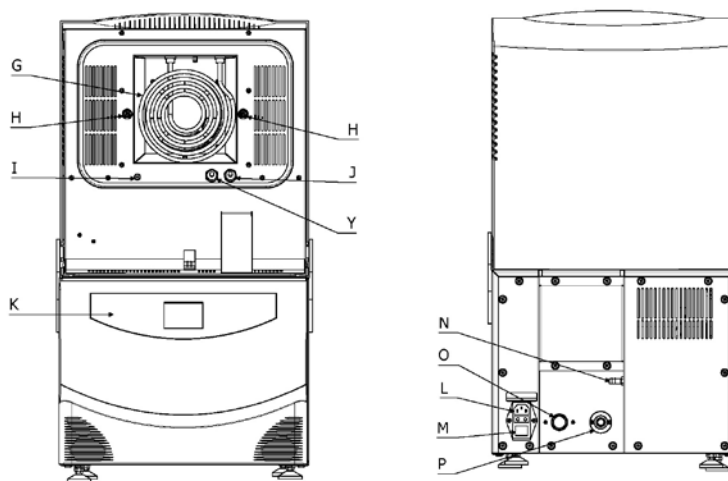
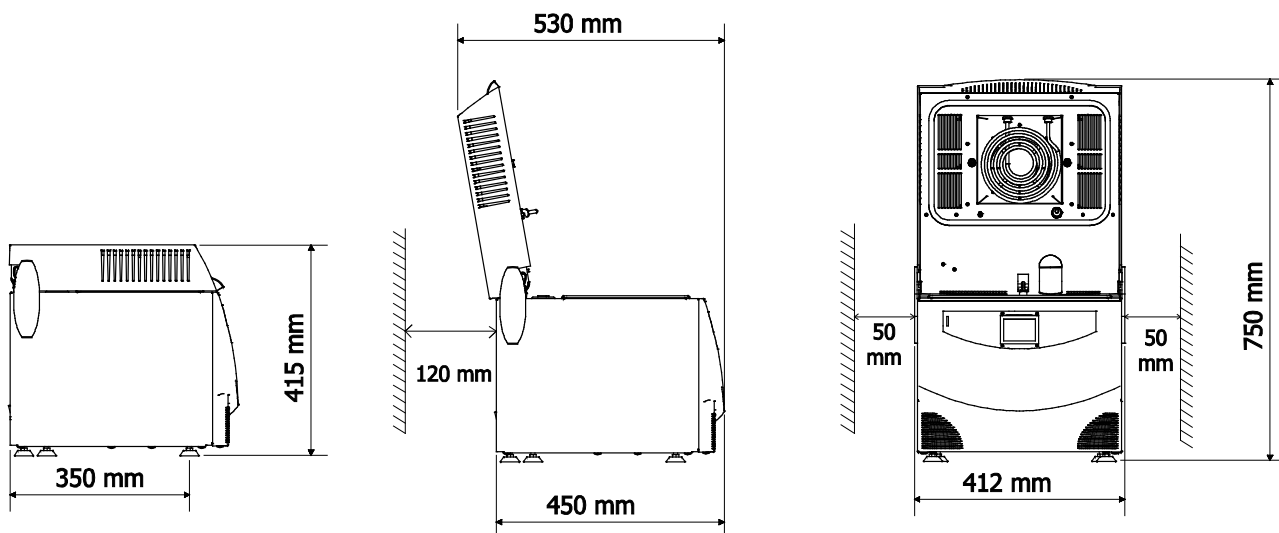

ÍNDICE

- 1. UTILIZAÇÃO PREVISTA E DESTINAÇÃO DE USO DO DISPOSITIVO**
- 2. SEGURANÇA**
 - 2.1 MARCAÇÃO DE SEGURANÇA
 - 2.2 DISPOSITIVOS DE SEGURANÇA
 - 2.3 ELIMINAÇÃO
- 3. DADOS TÉCNICOS**
- 4. DESEMBALAGEM**
- 5. COMPONENTES**
- 6. INSTALAÇÃO**
 - 6.1 CONEXÕES
12
 - 6.2 ENCHIMENTO DO RESERVATÓRIO DE DETERGENTE
- 7. FUNCIONAMENTO DO APARELHO**
 - 7.1 PAINEL DE COMANDOS
13
 - 7.2 SELEÇÃO DO IDIOMA
 - 7.3 SELEÇÃO DO CICLO
 - 7.4 DEFINIÇÃO PADRÃO DOS CICLOS
 - 7.5 MODIFICAÇÃO DOS CICLOS
 - 7.6 DEFINIÇÃO DE PARTIDA ATRASADA
- 8. INSTRUÇÕES DE USO**
- 9. MANUTENÇÃO**
 - 9.1 LIMPEZA
 - 9.2 LIMPEZA DO TANQUE
 - 9.3 LIMPEZA DO FILTRO DO TANQUE
 - 9.4 LIMPEZA DO FILTRO DE ENTRADA DE ÁGUA
 - 9.5 LIMPEZA DA SONDA
 - 9.6 MANUTENÇÃO PROGRAMADA
- 10. SINALIZAÇÕES – ERROS**
 - 10.1 SINALIZAÇÕES
 - 10.2 ERROS
 - 10.4 PROBLEMAS GENÉRICOS
- 11. PROCEDIMENTOS PARA O SERVIÇO E ASSISTÊNCIA TÉCNICA**
 - A. ACESSÓRIOS**
 - B. DESENHOS**

1 UTILIZAÇÃO PREVISTA E DESTINAÇÃO DE USO

DESTINAÇÃO DE USO

O tanque multifuncional foi projetado para remover fisicamente os resíduos orgânicos e inorgânicos e secar a instrumentação utilizada em âmbito médico, dental, estético e veterinário.

O dispositivo, através de deterção e ultrassom, permite limpar em pontos de difícil acesso para a limpeza manual e sem os riscos causados pelo manuseio dos instrumentos contaminados.

O dispositivo pode memorizar 3 ciclos, que podem ser definidos pelo utilizador.

As fases principais são:

DETERSÃO	Fase que reduz em mais de 90% a presença de contaminação microbiana. Tal fase remove o material orgânico e inorgânico.
ENXAGUAMENTO	Tal fase remove eventuais resíduos de detergente presentes no tanque.
SECAGEM	Depois do enxaguamento, os dispositivos devem ser secos para eliminar os resíduos de água que podem comprometer o sucessivo processo de esterilização





O tanque deve ser utilizado exclusivamente para a deterção de instrumentos e materiais compatíveis com o sistema de lavagem por ultrassom e, de um modo geral, exclusivamente para os usos previstos pelo fabricante.

2

SEGURANÇA

	O aparelho não deve ser utilizado em atmosfera potencialmente explosiva.
	Posicionar o aparelho longe de fontes de calor ou de radiações eletromagnéticas.
	Posicionar o equipamento de modo que o painel de comando e o ecrã possam ser vistos com clareza pelo operador.
	O sistema elétrico deve ser conforme com a norma vigente; verificar se o sistema é adequado às características do dispositivo.
	Controlar a integridade do cabo de alimentação.
	Não utilizar detergentes inflamáveis
	Não introduzir ácidos (por ex.: HCl) ou cloretos no tanque
	Não inserir objetos que entrem em contacto com o fundo do tanque
	O produtor é responsável pelo produto introduzido no mercado conforme a norma vigente. A <u>responsabilidade extingue-se</u> quando são realizadas operações no dispositivo, ou em partes dele, por <u>pessoal não qualificado</u> ou quando são <u>utilizadas peças sobressalentes não originais</u> .
	NÃO ABRIR O APARELHO Em caso de falhas ou perigo de intrusão de líquido no aparelho, em caso de manutenção e limpeza do aparelho, desconectar o cabo de alimentação elétrica.
	Não remover a placa
	Antes de qualquer intervenção, desinserir o cabo de alimentação da tomada de corrente.
	Seguir as indicações apresentadas na ficha de segurança do líquido detergente utilizado.
	O ultrassom em determinadas condições pode produzir ruídos desagradáveis para a audição. Usar EPI adequados.

2.1 Marcação de segurança

	<p>TENSÃO PERIGOSA</p>
 <p>ATTENZIONE ATTENTION ATTENTION ACHTUNG</p> <p>ALTA TEMPERATURA HIGH TEMPERATURES TEMPERATURES ELEVÉES HOHE TEMPERATUR</p>	<p>ALTA TEMPERATURA</p>
	<p>LIGAÇÃO À TERRA</p>

2.2 Dispositivos de segurança

-) Sensor de abertura da porta
-) Termóstatos de segurança
-) Sistema de controlo de carga de água

2.3 Eliminação



Este produto está submetido à diretiva 2002/96/EC do Parlamento europeu e do Conselho da União europeia a respeito dos resíduos de equipamentos elétricos (REEE). Nas jurisdições que adotam tal diretiva, o produto foi lançado no mercado em data posterior ao dia 13 de agosto de 2005 e não deve ser eliminado como resíduo doméstico não reciclável. Utilizar as estruturas locais REEE de recolha para a eliminação deste produto ou seguir as disposições vigentes.

3

DADOS TÉCNICOS**MECÂNICOS**

<i>Temperatura de trabalho</i>	+5°C ÷ +30°C
<i>Humidade relativa MÁX a 30°C</i>	80%
<i>Dimensões totais (LxHxP)</i>	415 x 415 x 530 mm
<i>Altura com a tampa aberta</i>	750 mm
<i>Profundidade com tampa aberta</i>	530 mm
<i>Peso (reservatórios vazios)</i>	20 kg

ELÉTRICOS

<i>Tensão de alimentação</i>	230 V a.c. +/-10 % single phase
<i>Potência MÁX. absorvida</i>	1 kW
<i>Frequência</i>	50 / 60 Hz
<i>Cabo de alimentação</i>	2 + 1 x 1mm ²
<i>Fusíveis</i>	6.3 A (5 x 20)

ULTRASSOM

<i>Nº transdutores</i>	4
<i>Frequência</i>	39 KHz

ALIMENTAÇÃO DE ÁGUA

<i>Pressão da água</i>	1.5÷2 bar
<i>Condutividade da água</i>	> 50 µS/cm
<i>Temperatura MÁX</i>	+30°C
<i>Dimensões do tubo de alimentação</i>	3/4 G - comprimento 3 m

TANQUE

<i>Volume do tanque</i>	9 l (Aço inox AISI 316)
<i>Volume de carga de água</i>	6 l

RESERVATÓRIO DE DETERGENTE

<i>Volume</i>	1.5 l + 0.5 l (reserva)
---------------	---------------------------

<i>Ciclos realizáveis com reservatório cheio</i>	Percentual selecionado	Ciclos executáveis*
	1%	≈25
	2%	≈12
	3%	≈8
	4%	≈6
	5%	≈5
	6%	≈4

<i>Material</i>	Polietileno
-----------------	-------------

FILTROS

<i>Filtro do tanque</i>	Aço inox AISI 304
-------------------------	-------------------

A embalagem deve ser manuseada com cuidado a fim de evitar impactos, rolamentos ou quedas.

O dispositivo é sustentado por uma palete de madeira e acondicionado numa caixa de cartão ondulado e reforçado internamente por compostos de cartão.

Abrir o cartão ondulado, remover as partes de reforço e extrair o dispositivo utilizando exclusivamente as correias fornecidas com o equipamento.



A movimentação do aparelho só deve ser feita com a utilização das correias. Nunca elevar segurando o dispositivo pelo quadro de comandos. Tal operação errada pode danificar o equipamento.



A embalagem deve ser conservada durante todo o período da garantia. O fabricante não aceita devoluções sem a embalagem original.



Não utilizar aparelhos que apresentam danos evidentes causados pelo transporte.



Remover a embalagem e controlar o estado do aparelho.

CONTEÚDO:

- **TANQUE MULTIFUNCIONAL**
- **MANUAL DE USO:** Deve ser lido atentamente pelo utilizador e guardado num local acessível a todos os operadores que trabalham com o dispositivo.
- **DECLARAÇÃO DE CONFORMIDADE:** deve ser conservada.
- **REGISTO DE INSTALAÇÃO - TESTE E CONDIÇÕES DE GARANTIA:** Deve ser preenchido no momento da instalação da máquina conforme as indicações do formulário.
- **GUIA RÁPIDO DE UTILIZAÇÃO:** Deve ser conservado nas proximidades da máquina.
- Tubo de alimentação de água
- Tubo de descarga
- Tubo de alívio do detergente
- Cabo de alimentação
- Cesta padrão
- Cesta porta-fresas
- Embalagem de detergente aconselhado

05**DESCRIÇÃO DOS COMPONENTES**

Consultar o **Apêndice B – DESENHOS**

G	Resistência de secagem
H	Bicos de água
I	Bico de detergente
J -Y	Sonda
K	Teclado e LCD
L	Interruptor geral
M	Ficha de alimentação com porta-fusíveis
N	Alívio do reservatório de detergente com função de controlo de fluxo
O	Entrada de água (3/8 G)
P	Conexão de descarga
R	Mola de gás
U	Guarnição da tampa
V	Coletor de detergente
Z	Recipiente inox



O aparelho não deve ser utilizado em atmosfera potencialmente explosiva.



Posicionar o aparelho longe de fontes de calor ou de radiações eletromagnéticas.



Posicionar o aparelho de modo que o painel de comando e o ecrã possam ser vistos com clareza pelo operador.



O sistema elétrico deve ser conforme com a norma vigente; verificar se o sistema é adequado às características do dispositivo.

Abrir a tampa e extrair os acessórios contidos no tanque.

Posicionar sobre uma superfície perfeitamente horizontal, estável e resistente a cargas de pelo menos **35 kg**. Os suportes do dispositivo são reguláveis e permitem mínimos ajustes;



Uma inclinação errada causa a permanência de uma película de água no fundo do tanque com problemas de secagem.

Posicionar o dispositivo de modo que o operador possa inspecionar e limpar facilmente o tanque; o operador deve conseguir aceder à parte traseira do dispositivo para limpar o filtro.

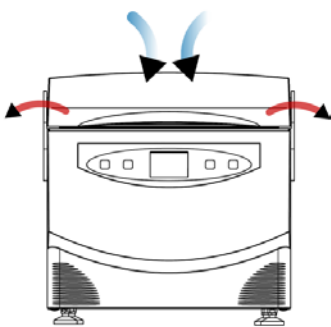

A secagem prevê a extração do ar da parte traseira e a descarga do ar quente pelos lados do dispositivo.

Deixar pelo menos 50 mm de espaço livre nos lados.

6.1 Conexões

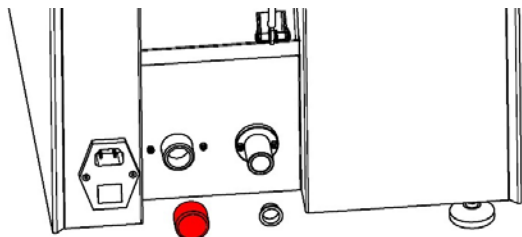

Remover os tampões de proteção.

Tubo de carga de água.

Conectar o tubo ao dispositivo (O) inserindo a respetiva guarnição de borracha. Conectar a outra extremidade à torneira de alimentação.

OPCIONAL: sistema de bloqueio de emergência do fluxo de água (WATER BLOCK). Tal dispositivo deve ser instalado imediatamente a jusante da torneira de alimentação em posição vertical. Ver as instruções do dispositivo para obter mais informações sobre a sua instalação e utilização.

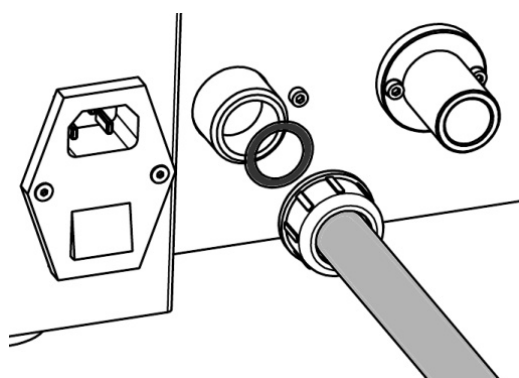

Tubo de descarga de água.

Remover o tampão de proteção. Conectar o tubo ao dispositivo (P). Conectar a outra extremidade à descarga. Fissare IL TUBO em modo stabile.



Instale o sifão como mostrado na figura

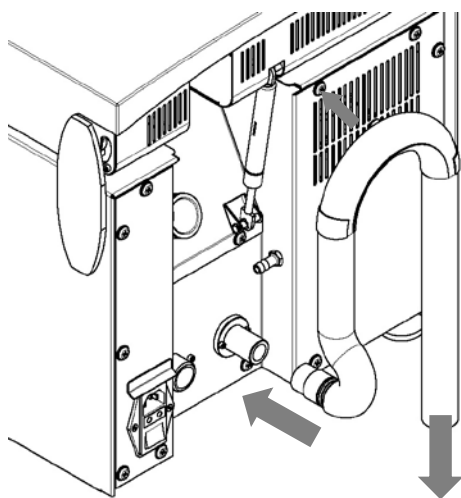

Tubo de alívio do reservatório de detergente

Colocar o tubo de alívio transparente fornecido com o equipamento num ponto visível à altura do plano de apoio da máquina ou em posição inferior. Não obstruir ou deixar mergulhar no líquido. O tubo de alívio tem também a função de controlo de fluxo; quando o reservatório do detergente está cheio e insere-se mais detergente, ele é descarregado pelo tubo de alívio.

Cabo de alimentação



Controlar a integridade do cabo de alimentação.

Conectar o cabo de alimentação à tomada situada na parte traseira do dispositivo (M).



Não conectar extensões, reduções ou adaptadores

Ligar a máquina através do respetivo interruptor (L) .

Abrir a torneira de alimentação de água e controlar se o tubo de carga não apresenta fugas (se houver fugas, apertar mais as conexões e controlar se as guarnições estão presentes). Controlar a presença do filtro no tanque e a sua limpeza.

6.2 Enchimento do reservatório de detergente:

O reservatório possui uma capacidade de aproximadamente 2 l, dos quais 0.5 l é de reserva.

Durante o enchimento, o dispositivo deve estar ligado e exibir 'SELEÇÃO CICLO'.



LIGAR SEMPRE A MÁQUINA ANTES DE CARREGAR O RESERVATÓRIO DO DETERGENTE

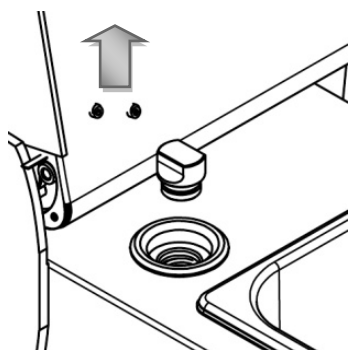

Abrir a tampa do tanque e levantar o tampão (V) situado no lado esquerdo do tanque.

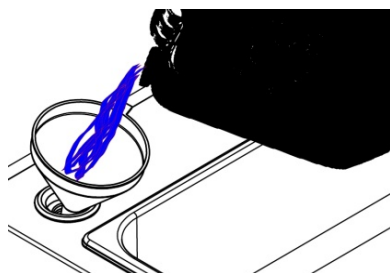

Inserir o líquido detergente (preferivelmente com o auxílio do funil fornecido com o equipamento) até um sinal sonoro/visual (no ecrã) avisar que o reservatório está cheio



Utilizar apenas líquidos recomendados pelo fabricante.



Não misturar líquidos dentro do reservatório, pois as reações químicas resultantes podem provocar danos consideráveis ao dispositivo.

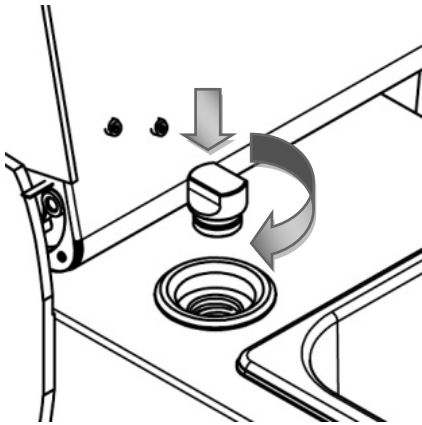

Pressionar e rodar ligeiramente para fechar o tampão de entrada de detergente.



É importante fechar o tampão de entrada de detergente para evitar que o detergente se cristalice; a cristalização do detergente pode causar obstruções e danificar alguns componentes.



7 FUNCIONAMENTO DO APARELHO

O dispositivo multifuncional possui uma tampa que pode ser erguida para dar acesso ao tanque de lavagem.

Dentro do tanque de lavagem é necessário posicionar o respectivo cesto, dotado de suportes de borracha, enchido com os objetos que devem ser limpos.

O dispositivo multifuncional possui um reservatório interno específico para conter um detergente que é dosado e injetado automaticamente no tanque de lavagem durante o ciclo.

Uma lavagem completa prevê as fases apresentadas na tabela seguinte.

FASE	SÍMBOLO	DESCRIÇÃO	DURAÇÃO																																			
1		<p>Carregamento de água</p> <p>A água entra no tanque superando a borda do cesto em cerca de 2 mm. O volume total é de cerca de 6 l.</p>	<p>1.5 min (P entrada = 2.5 bar)</p>																																			
2		<p>Entrada de detergente</p> <p>Uma bomba dosa automaticamente e transfere do reservatório interno para o tanque a quantidade definida de detergente:</p> <table border="1" data-bbox="534 1310 1133 1848"> <thead> <tr> <th>Percentual selecionada</th> <th>Volume (ml)</th> <th>Ciclos executáveis*</th> </tr> </thead> <tbody> <tr> <td>1%</td> <td>60</td> <td>≈25</td> </tr> <tr> <td>2%</td> <td>120</td> <td>≈12</td> </tr> <tr> <td>3%</td> <td>180</td> <td>≈8</td> </tr> <tr> <td>4%</td> <td>240</td> <td>≈6</td> </tr> <tr> <td>5%</td> <td>300</td> <td>≈5</td> </tr> <tr> <td>6%</td> <td>360</td> <td>≈4</td> </tr> </tbody> </table> <p><i>*Com o reservatório cheio (1500 ml)</i></p>	Percentual selecionada	Volume (ml)	Ciclos executáveis*	1%	60	≈25	2%	120	≈12	3%	180	≈8	4%	240	≈6	5%	300	≈5	6%	360	≈4	<table border="1" data-bbox="1236 1321 1380 1825"> <thead> <tr> <th>%</th> <th>seg</th> </tr> </thead> <tbody> <tr> <td>1</td> <td>80</td> </tr> <tr> <td>2</td> <td>160</td> </tr> <tr> <td>3</td> <td>240</td> </tr> <tr> <td>4</td> <td>320</td> </tr> <tr> <td>5</td> <td>400</td> </tr> <tr> <td>6</td> <td>480</td> </tr> </tbody> </table>	%	seg	1	80	2	160	3	240	4	320	5	400	6	480
Percentual selecionada	Volume (ml)	Ciclos executáveis*																																				
1%	60	≈25																																				
2%	120	≈12																																				
3%	180	≈8																																				
4%	240	≈6																																				
5%	300	≈5																																				
6%	360	≈4																																				
%	seg																																					
1	80																																					
2	160																																					
3	240																																					
4	320																																					
5	400																																					
6	480																																					

3		<p>Aquecimento</p> <p>O dispositivo realiza por 5 minutos o aquecimento e uma primeira descontaminação dos instrumentos. Quando não alcança a temperatura, o aquecimento continua também durante a lavagem.</p>	5 min ¹
4	 <p>A PISCAR</p>	<p>Desgaseificação (DEGAS)</p> <p>O dispositivo procede por 5 minutos ativando de modo intermitente o ultrassom. Este processo reduz os gases dissolvidos no líquido melhorando a eficiência da lavagem sucessiva.</p>	5 min ¹
4S	<p>PRESSIONAR START PARA CONTINUAL</p>	<p>STANDBY</p> <p>Esta fase inovadora permite gerir processos importante tais como:</p> <ul style="list-style-type: none"> - Manter os instrumentos no líquido de lavagem (MOLHO) - Adicionar instrumentos (ATENÇÃO: MÁX 1 KG de aço) <p>PARA SAIR DA FASE DE STANDBY E CONCLUIR O CICLO AUTOMATICAMENTE É NECESSÁRIO PRESSIONAR START.</p>	
5		<p>Lavagem por ultrassom</p> <p>fase de lavagem através de cavitação ultrassónica.</p> <p>SWEEP</p> <p>O ultrassom tem frequência modulada para reduzir os efeitos negativos das ondas estacionárias e aumentar a distribuição da energia ultrassónica no líquido de lavagem.</p> <p>A limpeza é mais eficiente (melhora a cavitação)</p>	de 1 min a 30 min
6		<p>Descarga</p> <p>O tanque esvazia-se automaticamente</p>	≈ 1.5 min

7		<p>Segundo carregamento de água</p> <p>O tanque é enchido novamente para enxaguar os instrumentos</p>	<p>1.5 min (P entrada = 2.5 bar)</p>
8		<p>Enxaguamento por ultrassom</p> <p>Ativação por breve período do ultrassom; enxaguamento por cavitação.</p>	<p>1 min</p>
9		<p>Descarga</p> <p>O tanque esvazia-se automaticamente</p>	<p>≈ 1.5 min</p>
10		<p><u>Secagem</u></p> <p>Para secar os instrumentos, a máquina gera um fluxo de ar quente que toca os objetos e retira deles a humidade em forma de vapor.</p>	<p>15 min</p>

Notas:

1 As fases de aquecimento e desgaseificação, se ambas estiverem definidas, são realizadas simultaneamente durante 5 minutos no total.

7.1 Painel de comandos

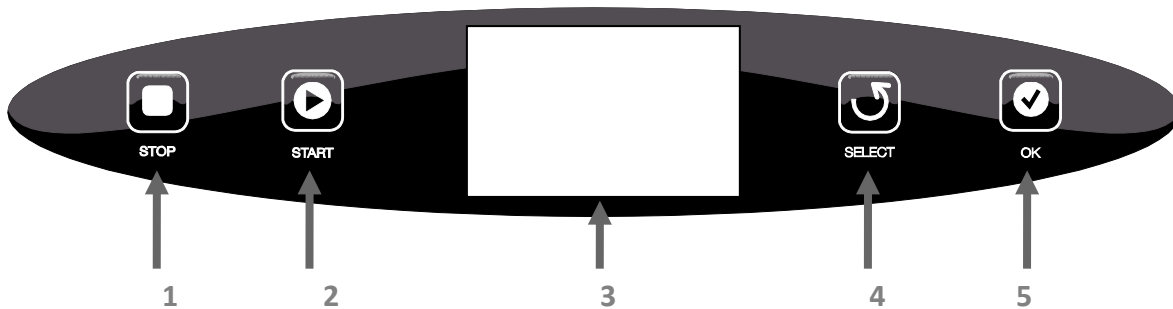

TECLAS DE INÍCIO/INTERRUPÇÃO DO CICLO

1	STOP - ANULA O CICLO EM EXECUÇÃO
2	START - INÍCIO DO CICLO

TECLAS DE PROGRAMAÇÃO

4	SELECT - BOTÃO DE NAVEGAÇÃO
5	OK - CONFIRMAR A SELEÇÃO E PASSAR PARA A SELEÇÃO SUCESSIVA
3	ECRÃ

7.2 Seleção do idioma

Pressionar **STOP** por 8 segundos.

O ecrã exibe o idioma definido.

Pressionar **SELECT** para percorrer os idiomas disponíveis.

Pressionar **OK** para confirmar o idioma selecionado.

7.3 Seleção do ciclo

No momento da ligação, aparece no ecrã o logótipo do fabricante e a versão do firmware.

Após 3 segundos, o ecrã exibe:

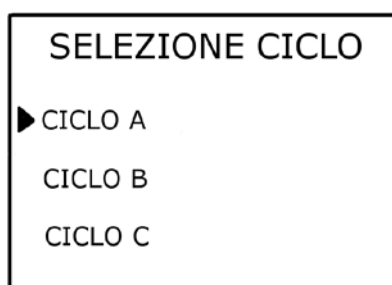

Pressionar **SELECT** para percorrer os programas.

Pressionar **START** para iniciar o ciclo selecionado.

7.4 Definição padrão dos ciclos

O dispositivo é emitido com as seguintes definições de fábrica:

	A	B	C
Standby	ON	OFF	OFF
Entrada de detergente	1 %	1 %	1 %
Aquecimento	ON	OFF	ON
Função Degas	SIM	SIM	SIM
Função SWEEP	NÃO	SIM	NÃO
Lavagem por ultrassom	20 min	20 min	5 min
Secagem	SIM	SIM	SIM

As definições podem ser modificadas à vontade para todos os ciclos.

7.5 Modificação dos ciclos

Selecionar o ciclo que se deseja modificar.

Pressionar o botão **OK** para visualizar o MENU.

Definições disponíveis:

Descrição	Definições	Step
Standby	ON - OFF	-
Entrada de detergente	0 ÷ 6 %	1%
Aquecimento	ON - OFF	-
Função Degas	SIM - NÃO	-
Função SWEEP	SIM - NÃO	-
Lavagem por ultrassom	0 ÷ 30 min	1 min
Secagem	SIM - NÃO	-

Pressionar a tecla **OK** para percorrer os parâmetros do ciclo.

Pressionar a tecla **SELECT** para modificar o valor do parâmetro selecionado.

O menu dos parâmetros e o menu das definições são de deslizamento circular.

Após concluir as definições, selecionar EXIT e pressionar **SELECT** para sair do MENU.

As modificações serão guardadas.

7.6 Definição PARTIDA ATRASADA:

Pressionar **START** por 8 segundos.

Pressionar **SELECT** para percorrer os valores de 1 a 9 horas.

Pressionar **START** para iniciar a partida atrasada.

Durante a espera vai aparecer um temporizador para mostrar o tempo que falta para o início do ciclo.

ATENÇÃO: Em caso de falta de tensão, anula-se a partida atrasada.

8

INSTRUÇÕES DE USO

Abrir a torneira de alimentação de água. Controlar a presença do filtro no tanque e a sua limpeza. Posicionar os objetos que devem ser tratados no respetivo CESTO, se houver objetos de pequenas dimensões, utilizar o respetivo porta-fresas fornecido com o equipamento.

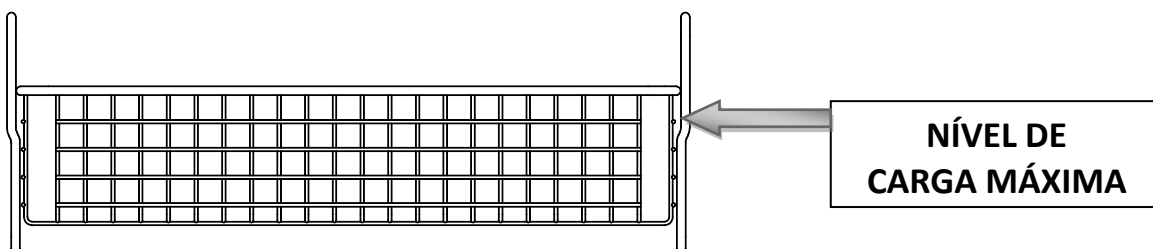

A carga deve ser feita distribuindo uniformemente os objetos a serem lavados, que não devem se chocar contra as paredes nem contra o fundo do tanque.

Inserir o cesto dentro do tanque prestando atenção para não criar contacto entre as paredes e o cesto.

É importante pré-tratar cimentos, alginatos e compósitos com líquidos específicos.

Se os objetos apresentarem sujidade grosseira, será necessário removê-la antes de inserir os instrumentos no cesto para não obstruir o filtro de descarga.

Para eliminar o contacto entre os pés do cesto de aço e o tanque de lavagem de aço são inseridos anéis de borracha apropriados. Se estiverem danificados ou ausentes, inserir novos anéis de borracha. A utilização errada pode causar danos ao tanque. Ligar a máquina através do respetivo interruptor (L) .

Iniciar o ciclo selecionado pressionando **START**; a máquina exibe a fase do ciclo que está a realizar e a contagem regressiva do tempo (tempo estimado) necessário para concluir o ciclo.

Quando o ciclo prevê a fase de STANDBY é necessário pressionar mais uma vez **START** (depois das fases de carga de água, entrada, degas e aquecimento) para passar para a fase de lavagem e terminar o ciclo definido.

No fim do ciclo exibe-se **END CYCLE OK** ' acompanhado de um sinal sonoro. Pressionar OK para colocar-se na seleção do ciclo.

Quando a porta é aberta com o dispositivo a funcionar, ocorre o bloqueio automático do processo em execução.

Ao fechar a tampa, o ciclo vai prosseguir exatamente a partir do ponto em que havia sido interrompido.



No fim do dia, fechar a torneira instalada a montante do dispositivo.



Não tocar os objetos, a tampa e a resistência durante a secagem. Perigo de queimaduras.



Esvaziar completamente o reservatório antes de inserir um detergente diferente do inserido anteriormente

Utilização de detergente diferente do contido no reservatório:

É possível utilizar detergentes diferentes do contido no reservatório.

No menu do ciclo que se pretende executar, na posição correspondente à entrada automática de detergente, definir como 'NÃO'.

Iniciar o ciclo; depois de alguns minutos (quando termina a fase de carga de água) o dispositivo emite um sinal sonoro; nesse momento é possível abrir a tampa e inserir diretamente no tanque o percentual (1% - 60ml) desejado de detergente.

Fechar a tampa para concluir o ciclo.

Esvaziamento do reservatório de detergente:

Utilizar o dispositivo; quando ele pedir para adicionar detergente e for necessário esvaziar completamente o reservatório de detergente, pressionar e manter pressionada a tecla **SELECT** e simultaneamente pressionar e manter pressionada a tecla **OK**.

Depois de 5 minutos ativa-se a bomba peristáltica; nessa fase apresenta-se um sinal sonoro intermitente que se interrompe apenas quando a fase termina; o detergente será descarregado diretamente no tanque através do bico situado na tampa (I).

Depois de aproximadamente 10 min., abrir ligeiramente a tampa (sem deixar intervir o sensor de abertura da tampa) e controlar se não sai detergente pelo bico.

Após terminar o esvaziamento, interromper o processo utilizando o botão **STOP**.

9

MANUTENÇÃO

9.1 Limpeza

A limpeza deve ser realizada com o dispositivo frio e o cabo de alimentação desconectado.



Utilizar detergentes não agressivos para o material plástico.



Utilizar detergentes adequados para o aço inox

9.2 Limpeza do tanque



Verificar a limpeza do tanque no fim de cada ciclo

Remover eventuais depósitos ou detritos para não permitir que no circuito de descarga entrem materiais que possam causar obstruções.

9.3 Limpeza do filtro do tanque



Verificar a limpeza do filtro no fim de cada ciclo

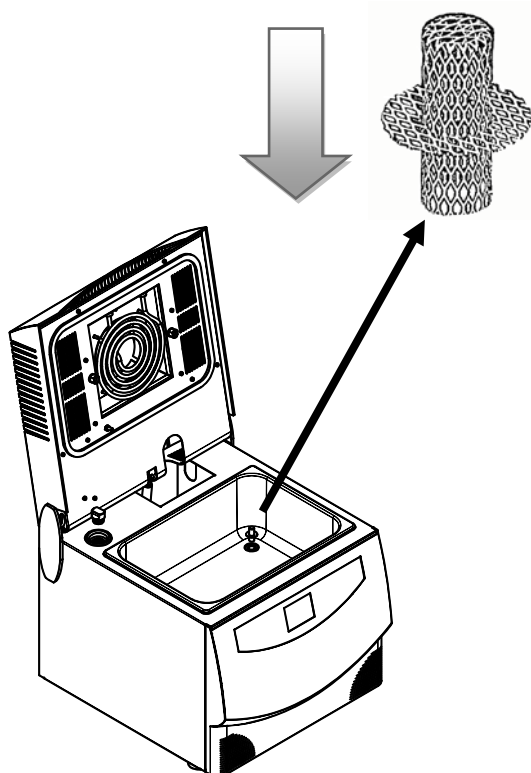

Levantar a tampa da máquina;

Remover os resíduos presentes no tanque.

Extrair o filtro metálico presente no tanque puxando-o para cima conforme indicado na figura;

Lavar o filtro em água corrente para remover todas as impurezas presentes.

Recolocar o filtro do seu alojamento prestando atenção para inserir a parte aberta do filtro dentro da conexão de descarga e a fechada à vista no tanque.

9.5 Limpeza do filtro de entrada de água

Deve-se controlar periodicamente

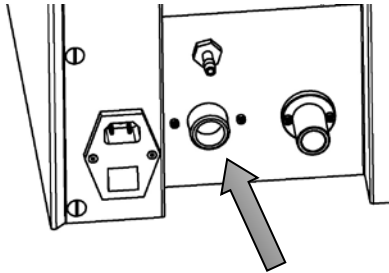

Fechar a alimentação de água, remover o tubo de carga de água, verificar se o filtro (O) está limpo.

Caso contrário, extraí-lo com o auxílio de uma pinça sem forçar e limpá-lo com água.

Montar novamente o filtro e o tubo de alimentação.

9.6 Limpeza da sonda de nível

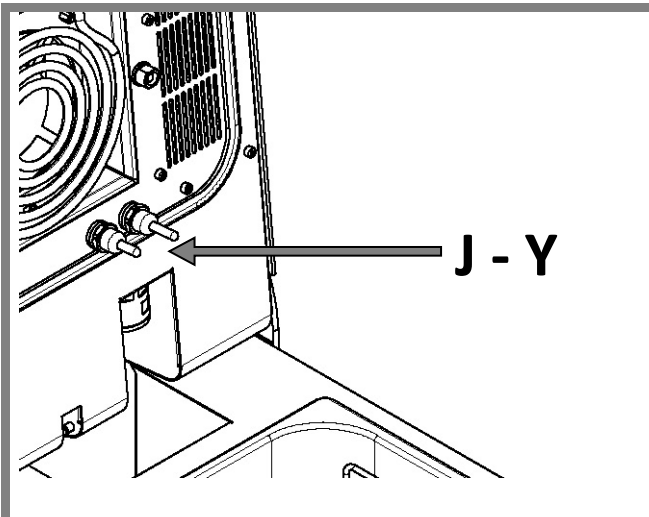

Controlar periodicamente a **SONDA J - Y**.
 Limpar a parte de metal com produtos adequados para aço inox ou um decapante.
 Utilizar uma esponja (ligeiramente abrasiva).

9.7 Manutenção programada



Utilizar exclusivamente peças sobressalentes originais

Descrição	Frequência	Executor
Substituição do tubo da bomba peristáltica.	Anual	Técnicos autorizados
Controlo da ventoinha de secagem	Anual	Técnicos autorizados
Filtro do tanque	Se necessário	Utilizador
Guarnição do tampão de detergente	Se necessário	Utilizador
Guarnição da tampa	Se necessário	Técnicos autorizados



As operações de **manutenção e reparação** devem ser feitas com a máquina desconectada da alimentação elétrica.

Uma correta manutenção do dispositivo assegura o seu bom funcionamento e uma poupança segura em termos de tempo e custos devidos à assistência.

10

SINALIZAÇÕES – ERROS

10.1 Sinalizações



Ecrã	Causa	Solução
	<p>A tampa está aberta.</p>	<p>Fechar a tampa.</p>
	<p>O líquido detergente no reservatório é insuficiente (≤ 0.5 l)</p>	<p>Encher o reservatório do detergente e reiniciar o ciclo ou definir um ciclo sem detergente</p>
	<p>O reservatório de detergente está cheio.</p>	<p>Interromper o enchimento do reservatório de detergente. Se o enchimento prosseguir, o detergente vai sair pelo tubo traseiro do controlo de fluxo.</p>

10.2 Erros

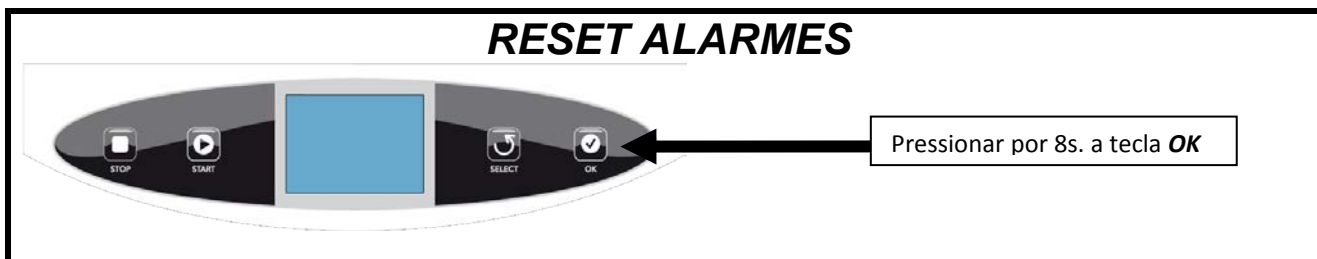
Em caso de sinalização de erro, é necessário efetuar o reset do dispositivo para poder iniciar um novo ciclo.

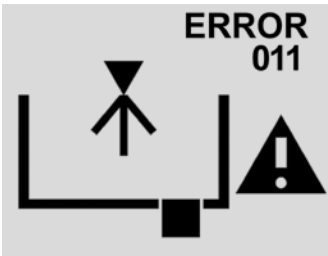

Ecrã	Causas	Soluções
	<p>Anomalia na entrada de água</p> <ul style="list-style-type: none"> - Torneira fechada - Filtros obstruídos - Anomalia na pressão do sistema de água 	<ul style="list-style-type: none"> - Controlar se a torneira está aberta. - Limpar o filtro da entrada de água. - Controlar se a pressão da água está dentro dos limites indicados. Se for insuficiente, consultar um canalizador para avaliar as possíveis soluções. - Controlar se o Water Block não está bloqueado (OPCIONAL). - Verificar se não há água no tanque e iniciar um novo ciclo
	<p>Anomalia no nível da água</p> <ul style="list-style-type: none"> - O dispositivo foi deslocado ou inclinado durante a lavagem. - Foram adicionados muitos instrumentos depois do carregamento da água. 	<ul style="list-style-type: none"> - Verificar se não há água no tanque e reiniciar o ciclo - Não adicionar instrumentos durante o ciclo.
	<p>Anomalia na descarga da água</p> <ul style="list-style-type: none"> - Filtros obstruídos - Quebra de bomba de descarga 	<ul style="list-style-type: none"> - Limpar o filtro do tanque. - Verificar se não há água no tanque e reiniciar um ciclo.

Ecrã	Causas	Soluções
	<p>Anomalia na entrada de água</p>	<p>SONDA J - Y. Limpar a parte de metal com produtos adequados para aço inox ou um decapante. Utilizar uma esponja (ligeiramente abrasiva).</p>
	<p>Anomalia na entrada de água Anomalia na pressão do sistema de água</p>	<p>SONDA J - Y. Limpar a parte de metal com produtos adequados para aço inox ou um decapante. Utilizar uma esponja (ligeiramente abrasiva). Controlar se a pressão da água está dentro dos limites indicados. Se for insuficiente, consultar um canalizador para avaliar as possíveis soluções.</p>

ELIMINAÇÃO DE ÁGUA EM VASK
INICIE A BOMBÁ DE DESCANSO POR 30 SEGUNDOS



10.4 Problemas genéricos

Problemas	Possíveis causas	Solução
Limpeza insuficiente	- Água calcária, halos brancos presentes nos instrumentos	- Instalar um amaciador a montante. - Alguns detergentes podem reduzir este fenómeno
	- Presença de elementos não pré-tratados (cimentos, alginatos)	- Pré-tratar com detergentes adequados.
	- Definições do ciclo incorretas	- Alterar os parâmetros aumentando o tempo de lavagem.
	- Não se percebe o ruído do ultrassom durante a fase de lavagem	- Contactar o serviço de assistência técnica
Secagem insuficiente	- Carga excessiva, presença de gotas entre os instrumentos	- Reduzir a carga
	- Instalação incorreta, presença de uma película de água no fundo do tanque depois da descarga.	- Posicionar o dispositivo corretamente, modificar a altura dos pés
	- Não se percebe o fluxo de ar nas aberturas laterais da tampa	- Contactar o serviço de assistência técnica
Alguns instrumentos são danificados	- Instrumentos inadequados para a lavagem por ultrassom (por ex.: espelhos)	- Não lavar com ultrassom instrumentos inadequados

PROCEDIMENTOS PARA O SERVIÇO E ASSISTÊNCIA TÉCNICA

Em caso de falha ou revisão, contactar diretamente a assistência telefónica.

TELEFONE:	+39 0521 8380
FAX:	+39 0521 833391
@	service@tecnogaz.com

A assistência técnica avaliará a reentrada em sede ou a intervenção de um técnico e inspeção da máquina para estabelecer um orçamento que será sucessivamente encaminhado ao revendedor que, por sua vez, transmitirá ao cliente final para conhecimento e subscrição.

Após receber o orçamento para aceitação, o dispositivo será colocado em serviço e expedido dentro do prazo indicado no módulo de orçamento.

Se for necessário expedir o dispositivo ao estabelecimento, seguir as indicações obrigatórias:

- Caso a embalagem original não esteja mais disponível, utilizar uma semelhante. A mercadoria viaja com risco sob a responsabilidade do destinatário.
- Expedir só o tanque (não inserir nenhum componente pertencente ao kit de acessórios).
- Limpar bem o dispositivo antes de expedi-lo. Se chegar suja e com resíduos, o dispositivo será expedido de volta sem ser reparado ou será submetido a uma ação de limpeza e desinfeção.
- Descarregar sempre o reservatório do detergente.
- Indicar por escrito e inserir na embalagem um documento no qual esteja indicada a anomalia detetada com precisão ou o serviço que pretender utilizar.
- Enviar sempre com porte pago, caso contrário, as despesas de transporte serão debitadas.

Todas as embalagens que a fábrica receber serão eliminadas.

A máquina será expedida de volta com embalagem original (o custo da embalagem será cobrado) através do transportador escolhido pelo cliente.

A	ACESSÓRIOS	
	DESCRIÇÃO	CÓDIGO
	CESTO (180 mm X 280 mm H60 mm)	DVMA069
	GUARNIÇÕES DO PÉS	DFAA493
	PORTA-FRESAS (D 70 mm H 60 mm)	DVMA072
	TUBO DE CARGA (C 3 m)	CPLA002
	TUBO DE DESCARGA (c 0.8-2.7 m)	CPLA001
	CABO DE ALIMENTAÇÃO (C 2.5 m)	CECG006
	FUNIL	CPMG001
	WATER BLOCK (OPCIONAL)	DVMA092
	FILTRO DO TANQUE	DVMA115
	PORTA-TABULEIRO (OPCIONAL)	VM801ZVM
	Nº1 TABULEIRO (OPCIONAL)	SVMA070
	Multisteril CD Líquido detergente/desinfetante Diluição para lavagem por ultrassom: 1% Conteúdo 1 L Embalagem 6 un.	DM401ALP

B

DESENHOS

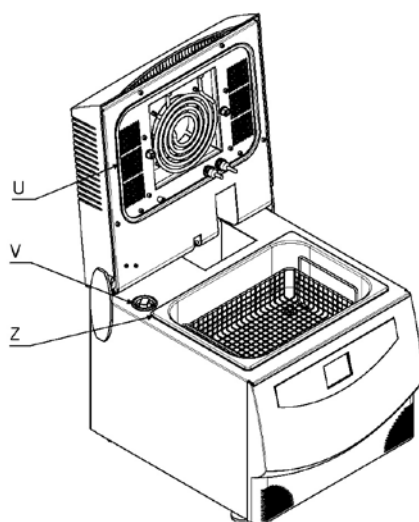
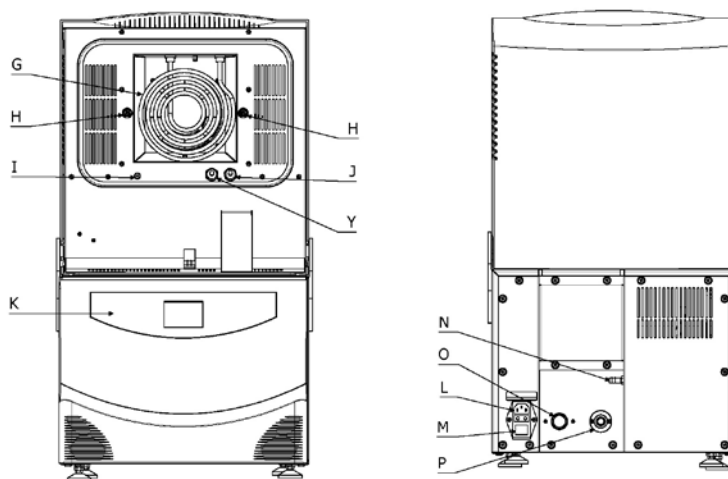
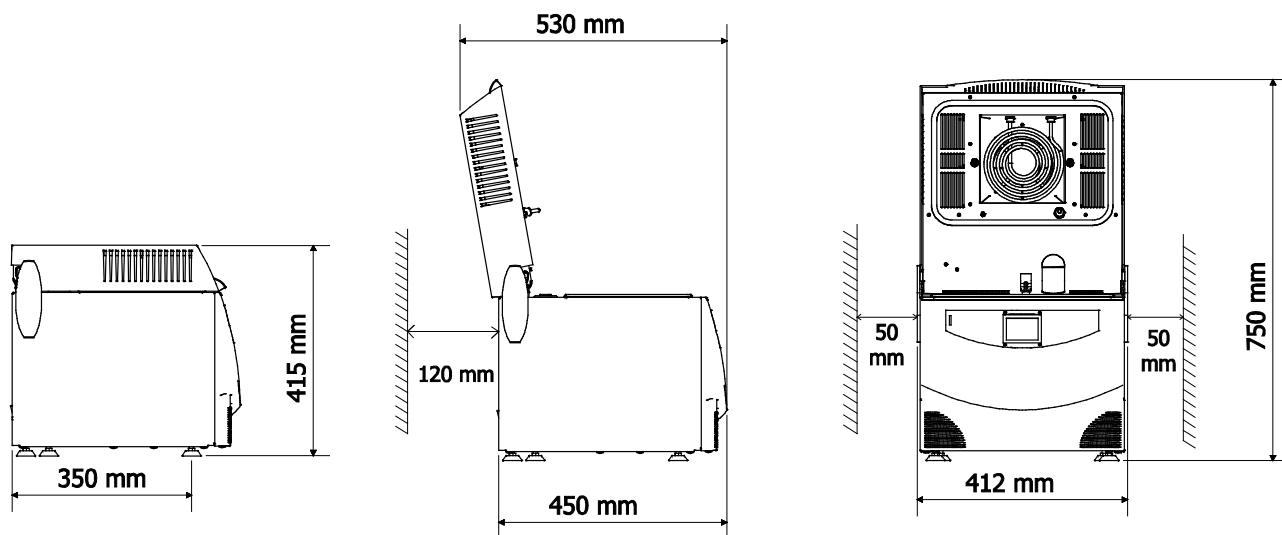



TECNO-GAZ S.p.A

www.tecnogaz.com

Sede | Headquarters

Strada Cavalli, n. 4
C.A.P. 43038
Sala Baganza
Parma- Italia

Stabilimento 2 | Factory 2

Via VIII Marzo, n. 4
C.A.P. 42025
Caviago

Reggio nell'Emilia Italia

Magazzino | Warehouse

Via Aldo Moro, n. 9
C.A.P. 43038
Sala Baganza
Parma Italia

I
EN
F
D
E
PT

Il presente manuale deve sempre accompagnare il prodotto, in adempimento alle Direttive Comunitarie Europee. TECNO-GAZ, si riserva il diritto di apporre modifiche al presente documento senza dare alcun pre-avviso. La ditta TECNO-GAZ si riserva la proprietà del presente documento e ne vieta l'utilizzo o la divulgazione a terzi senza il proprio benestare.

This manual must always be kept with the product, in complying with the Directives of European Community. TECNO-GAZ reserves the right to modify the enclosed document without notice. TECNO-GAZ reserves the property of the document and forbids others to use it or spread it without its approval.

Ce manuel doit toujours accompagner l'appareil conformément aux Directives de la Communauté européenne. TECNO-GAZ se réserve le droit d'y apporter des modifications sans aucun préavis. TECNO-GAZ se réserve la propriété de ce manuel. Toute utilisation ou divulgation à des tiers est interdite sans son autorisation.

Diese Anleitung muss dem Gerät in Übereinstimmung mit den Richtlinien der Europäischen Gemeinschaft beigelegt werden. TECNO-GAZ behält sich dar Recht vor ohne Vorankündigung Änderungen in dieser Dokumentation vorzunehmen. Die Firma TECNO-GAZ ist Eigentümer der vorliegenden Dokumentation und verbietet die Nutzung von Dritten oder die Weitergabe an Dritte ohne entsprechende Genehmigung.

El presente manual siempre deberá acompañar el producto al cual pertenece, cumpliendo las Directivas Comunitarias Europeas. TECNO-GAZ, reserva el derecho de aportar alteraciones al presente documento sin avisos previos. La empresa TECNO-GAZ reserva a sí los derechos de propiedad del presente documento prohibiendo su utilización o divulgación a terceros sin que haya expresado su consentimiento.

Este manual deve sempre acompanhar o produto, em conformidade com as directivas comunitárias. TECNO-GAZ reserva o direito de modificar o documento fechado, sem pré-aviso. TECNO-GAZ reserva a propriedade deste documento e proíbe o uso ou divulgação a terceiros sem o seu consentimento.